

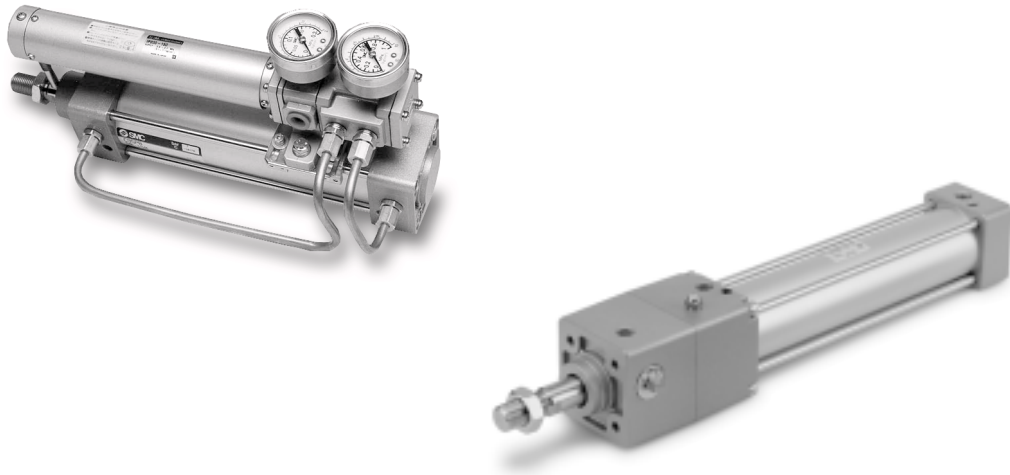

ISO/VDMA Cylinder *Series C95*

ø32, ø40, ø50, ø63, ø80, ø100, ø125, ø160, ø200, ø250

Conforming to ISO 6431/CETOP RP43P/VDMA 24562



Quick Reference
Guide

C55

C85

C76

CP95

C95

-X
(Made to Order)

D-
(Auto Switch)

Model Selection
Procedures

ISO Cylinder/Standard: Double Acting with Positioner

Series C95P

ø50, ø63, ø80, ø100

How to Order

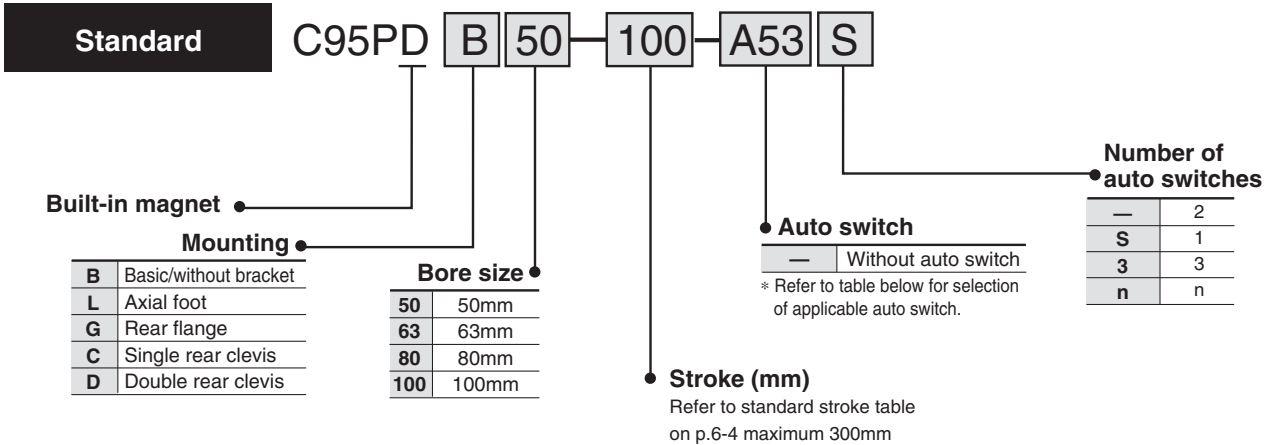

Applicable Auto Switches/Tie rod mounting

Style	Special function	Electrical entry	Indicator	Load voltage		Auto switch model	Lead wire (m)*			Applicable load	Mounting bracket	
				Wiring (Output)	DC		AC	0.5 (-)	3 (L)			5 (Z)
Reed switch	—	Grommet	Yes	3 wire (NPN) (Equiv. to NPN)	5V	—	A56	●	●	—	IC	ø32,ø40 BT-03
					12V	—	A53	●	●	●	Relay PLC	
				24V	5V,12V	100V,200V	A54	●	●	●		
					2 wire	5V,12V	—	A67	●	●	—	
Solid state switch	Diagnosis indication (2 colour) Water resistant (2 colour) With timer Diagnosis output (2 colour) Latch diagnosis output (2 colour)	Grommet	Yes	3 wire (NPN)	24V	5V,12V	—	F59	●	●	○	ø50,ø63 BT-05
								F5P	●	●	○	
				3 wire (PNP)	—	—	100V,200V	J51	●	●	○	
								J59	●	●	○	
				2 wire	24V	12V	—	F59W	●	●	○	
								F59W	●	●	○	
				3 wire (NPN)	5V,12V	—	—	F5PW	●	●	○	
								F5PW	●	●	○	
				3 wire (PNP)	24V	12V	—	J59W	●	●	○	
								J59W	●	●	○	
2 wire	24V	12V	—	F5BA	—	●	○					
				F5BA	—	●	○					
3 wire (NPN)	5V,12V	—	—	F5NT	—	●	○					
				F5NT	—	●	○					
4 wire (NPN)	—	—	—	F59F	—	●	○					
				F59F	—	●	○					
F5LF	—	—	—	F5LF	●	●	○					
				F5LF	●	●	○					

Table ①
Auto Switch Mounting Bracket for D-M9□

Bore size (mm)	Order No.
ø32, ø40	BMB5-032
ø50, ø63	BA7-040
ø80, ø100	BA7-063

Type	Special function	Electrical entry	Indicator light	Wiring (output)	Load voltage		Auto switch model		Lead wire length (m) (Note)			Applicable load	Mounting bracket	
					DC	AC	Electrical entry direction		0.5 (Nil)	3 (L)	5 (Z)			
							Vertical	Lateral						
Reed switch	—	Grommet	Yes	3 wire	—	5V	—	Z76	●	●	—	IC circuit	—	
														2 wire
No	5V, 12V	100V or less	—	—	Z80	●	●	—	—	IC circuit				
											Solid state switch	Diagnostic indication (2 colour indicator)	Grommet	Yes
Y7PV	Y7P	●	●	○										
3 wire (PNP)	—	—	100V,200V	Y69B	Y59B	●	●	○	—					
				Y7NWV	Y7NW	●	●	○						
2 wire	24V	12V	—	Y7PWV	Y7PW	●	●	○	IC circuit					
				Y7PWV	Y7PW	●	●	○						
3 wire (NPN)	5V,12V	—	—	Y7BWW	Y7BW	●	●	○	—					
				Y7BWW	Y7BW	●	●	○						
3 wire (PNP)	24V	12V	—	—	Y7BA	—	●	○	—					
				—	Y7BA	—	●	○						
Water resistant (2 colour indicator)	—	Connector and Grommet	Yes	2 wire	24V	5V, 12V	—	M9NV	M9N	●	●	○	IC circuit	Relay PLC
								M9PV	M9P	●	●	○		
								M9BV	M9B	●	●	○		

* Lead wire length 0.5m..... — (Example: A53)
3m..... L (Example: A53L)
5m..... Z (Example: A53Z)

○: Manufactured upon receipt of order.

Series C95P

Specifications

Application:

The positioner IP200 is capable of pneumatic positioning of the piston. Adjustable positions can be reached with high repeating accuracy. The piston stroke is in proportion to the air pressure input signal (0.02-0.01MPa). External forces on the position of the piston are reduced to a minimum by a special control system and an integrated function to revert the set position.

The IP200 shows excellent performance in remote control or standard control of flaps, proportioning devices, pumps, gears usw.

Specifications

- The bleed pressure acts directly onto the flapper plate. A change of the input signal will cause an instantaneous movement of the piston rod.
- easy and simple adjustment of neutral point and operation band from outside.
- Return spring is protected against accidental touches
- Positioner cylinder conforms to ISO and CETOP recommendations
- No change in dimensions with auto switch capability

Specifications

Fluid	Air 5µm filtration
Supply pressure "SUP" (MPa)	0.3 ~ 0.7
Signal pressure "SIG" (MPa)	0.02 ~ 0.1
Fluid temperature (°C)	+5 to +60
Linearity	< 2%*
Hystereses	< 1%*
Repeatability	< 1%*
Sensitivity	< 1%*
Port size	G1/4
Gauge port	G1/8
Primary pressure	0.5% with 0.5MPa
Flow rate (l/min)	250 with 0.5MPa
Leakage	< 18 with 0.5MPa
Bore Size (mm)	40 to 100
Cylinder stroke (mm)	25 to 300
Standard stroke (mm)	50/100/150/200/250/300
Max. possible stroke (mm)	300

*different in % related to full span.



Part No: Mounting Bracket, Mounting Accessories

Description	ø50	ø63	ø80	ø100
L	L5050	L5063	L5080	L5100
F,G	F5050	F5063	F5080	F5100
C	C5050	C5063	C5080	C5100
D	D5050	D5063	D5080	D5100
DS	DS5050	DS5063	DS5080	DS5100
ES	ES5050	ES5063	ES5080	ES5100
E	E5050	E5063	E5080	E5100
GKM	GKM16-32	GKM16-32	GKM20-40	GKM20-40
KJ	KJ16D	KJ16D	KJ20D	KJ20D
JA	JA50-16-150	JA50-16-150	JAH50-20-150	JAH50-20-150

Note 1) Two foot brackets required for one cylinder.

Note 2) Accessories for each mounting bracket are as follows.

Foot, Flange, Single clevis: Mounting bolts

Double rear clevis: (D,DS): Clevis pin

Note 3) GKM according to ISO 8140

Note 4) KJ according to ISO 8139

Note 5) Piston rod nut is standard

Weight accessories (kg)

Ø	50	63	80	100
L	0.38	0.46	0.89	1.09
F	0.47	0.58	1.30	1.81
C	0.37	0.60	1.07	1.73
D	0.45	0.71	1.28	2.11
E	0.42	0.52	0.94	1.40

Weight Table

Weight (kg)					
	Ø	50	63	80	100
	B		2.27	2.79	4.11
Weight each 50mm stroke		0.32	0.33	0.48	0.62

Example: C95PDB50-200

Cylinder Ø50mm, stroke 200mm

Bracket L

Weight = 2.72kg + (0.31kg × $\frac{200}{50}$) = 3.96kg

For dimensions of the brackets and accessories, please see C95S, page 1-206

Dimensions

Signal Pressure/Stroke Diagram

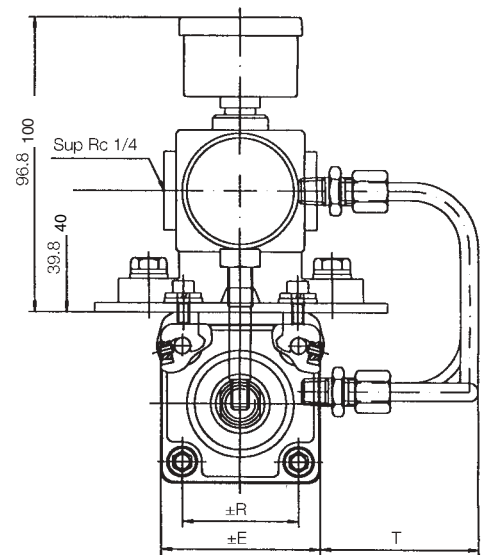
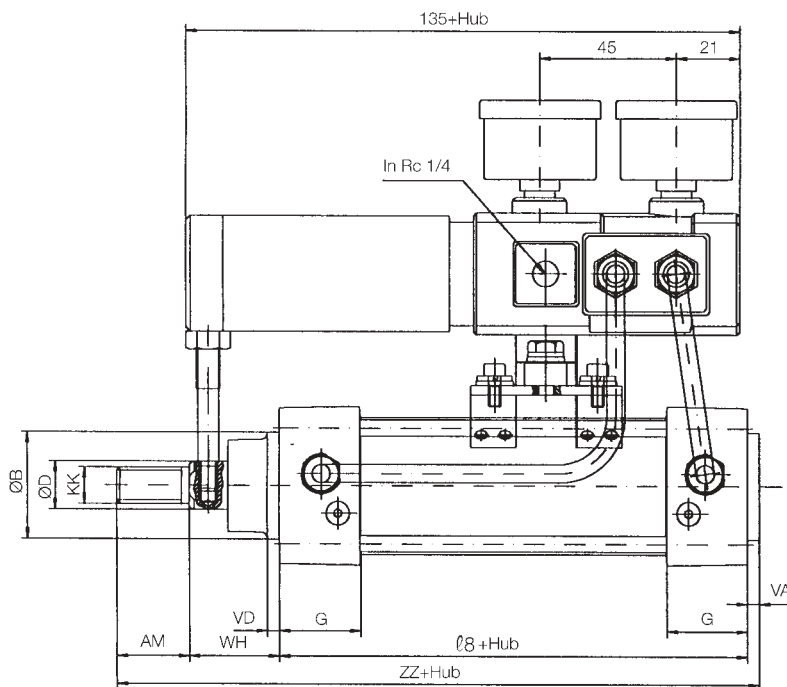
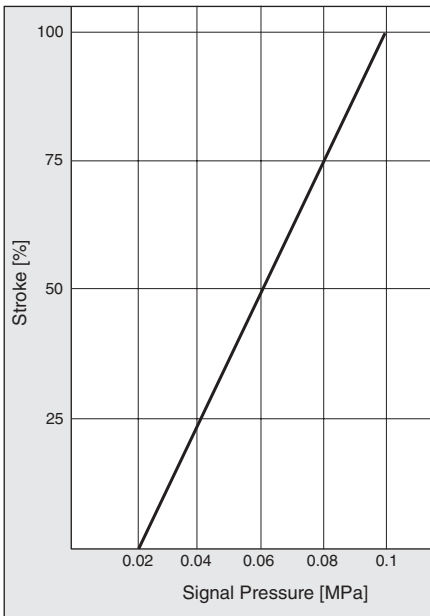

Ø	AM	ØB	ØD	±E	G	KK	l 8	±R	T	VA	VD	WH	ZZ
50	32	40	20	65	31.5	M16 x 1.5	106	46.5	53	4	6	37	179
63	32	45	20	75	31.5	M16 x 1.5	121	56.5	54	4	6	37	194
80	40	45	25	95	38	M20 x 1.5	128	72	54	4	8	46	218
100	40	55	30	114	38	M20 x 1.5	138	89	26	4	8	51	233

ISO Cylinder/Standard: Double Acting with Lock

Series C95N

ø32, ø40, ø50, ø63, ø80, ø100

How to Order

Standard C95ND B 32 100 W A53 S

Built-in magnet (points to 'B')

Mounting (points to 'B')

Bore size (points to '32')

Stroke (mm) (points to '100')

Rod specifications (points to 'W')

Auto switch (points to 'A53')

Number of auto switches (points to 'S')

Mounting	
B	Basic/without bracket
L	Axial foot
G	Rear flange
C	Single rear clevis
D	Double rear clevis
T	Trunion

Bore size	
32	32mm
40	40mm
50	50mm
63	63mm
80	80mm
100	100mm

Auto switch	
—	Without auto switch

* Refer to table below for selection of applicable auto switch.

Rod specifications	
—	Hard chrome as standard
W	Double/through rod

Number of auto switches	
—	2
S	1
3	3
n	n

Applicable Auto Switches/Tie rod mounting

Refer to standard stroke table on p.6-23.

Style	Special function	Electrical entry	Indicator	Load voltage			Auto switch model	Lead wire (m)*			Applicable load	Mounting bracket		
				Wiring (Output)	DC	AC		0.5 (-)	3 (L)	5 (Z)				
Reed switch	—	Grommet	Yes	3 wire (Equiv. to NPN)	—	5V	—	A56	●	●	—	IC	ø32,ø40 BT-03	
					—	12V	—	A53	●	●	●	Relay PLC		
				2 wire	24V	5V, 12V	—	A67	●	●	—			IC
					—	12V	200V or less	A64	●	●	—			
Solid state switch	—	Grommet	Yes	3 wire (NPN)	24V	5V, 12V	—	F59	●	●	○	IC	ø50,ø63 BT-05	
									3 wire (PNP)	—	100V, 200V			J51
				2 wire	—	12V	J59	●				●		
								3 wire (NPN)	—	5V, 12V	F59W	●		●
				3 wire (PNP)	—	12V	F5PW					●		●
								2 wire	24V	12V	—	J59W		●
				3 wire (NPN)	—	5V, 12V	F5BA							—
								3 wire (PNP)	—	12V	F5NT	—		●
				4 wire (NPN)	—	5V, 12V	F59F					●		●
								—	—	—	F5LF	●		●
				—	—	—	—					—		—
								—	—	—	—			

Table ①
Auto Switch Mounting Bracket for D-M9□

Bore size (mm)	Order No.
ø32, ø40	BMB5-032
ø50, ø63	BA7-040
ø80, ø100	BA7-063

Type	Special function	Electrical entry	Indicator light	Wiring (output)	Load voltage		Auto switch model		Lead wire length (m) (Note)			Applicable load	Mounting bracket							
					DC	AC	Vertical	Lateral	0.5 (Nil)	3 (L)	5 (Z)									
Reed switch	—	Grommet	Yes	3 wire	—	5V	—	—	Z76	●	●	—	IC circuit	—						
										2 wire	24V	—			100V	—	Z73	●	●	●
No	—	5V, 12V	100V or less	—	Z80	●	●	—	IC circuit											
						Solid state switch	—	Grommet		Yes	3 wire (NPN)	24V	5V, 12V	—	Y69A	Y59A	●	●	○	IC circuit
3 wire (PNP)	—	12V	Y69B	Y59B	●				●								○	—		
					2 wire				—		12V	Y7NWV	Y7NW	●	●	○	IC circuit			
3 wire (NPN)	—	5V, 12V	Y7PWV	Y7PW										●	●	○		—		
					3 wire (PNP)				—		12V	Y7BWV	Y7BW	●	●	○	—			
2 wire	—	12V	—	Y7BA										—	●	—		—		
					—	—	Connector and Grommet	Yes	3 wire (NPN)	24V	5V, 12V	—	M9NV	M9N	●	●	○		IC circuit	Relay PLC
3 wire (PNP)	—	12V	M9PV	M9P											●	●	○			
															2 wire	—	12V	M9BV		

* Lead wire length 0.5m..... — (Example: A53)
3m..... L (Example: A53L)
5m..... Z (Example: A53Z)

○: Manufactured upon receipt of order.

Cylinder Series C95N with lock

Cylinder Specifications

Bore Size [mm]	32, 40, 50, 63, 80, 100
Fluid	Air
Proof Pressure	1.5MPa
Max. operating pressure	1.0MPa
Min. operating pressure	0.08MPa
Piston speed	50 to 1000mm/s ^{note)}
Ambient and fluid temperature	Without autoswitch : -10°C to 70°C (without freezing) With autoswitch : -10°C to 70°C (without freezing)
Cushion	Double air side cushion
Stroke length tolerance	to 250: $^{+1.0}_0$, 251 to 1000: $^{+1.4}_0$
Bracket type	Basic type, Axial foot type, Front flange type, Rear flange type, Single clevis type, Double clevis type

Note) Load limits exist depending upon piston speed when locked, mounting direction and operating pressure.



Cylinder with lock

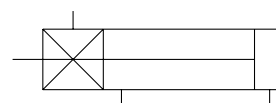

Lock Specifications

Lock actuation	Spring lock (exhaust lock)
Unlocking pressure	≥ 0.25 MPa
Locking pressure	≥ 0.20 MPa
Max. operating pressure	1.0MPa
Locking direction	2 Two-way

Standard Stroke

Bore Size [mm]	Standard Stroke [mm]	Max. Stroke*
32	25,50,75,100,125,150,175,200,250,300,350,400,450,500	700
40	25,50,75,100,125,150,175,200,250,300,350,400,450,500	800
50	25,50,75,100,125,150,175,200,250,300,350,400,450,500,600	1000
63	25,50,75,100,125,150,175,200,250,300,350,400,450,500,600	
80	25,50,75,100,125,150,175,200,250,300,350,400,450,500,600,700,800	
100	25,50,75,100,125,150,175,200,250,300,350,400,450,500,600,700,800	

Intermediate strokes are available.

* Please consult with SMC for longer strokes.

Stopping Accuracy

[mm]

Locking system	Piston speed [mm/s]			
	100	300	500	1000
Spring lock	± 0.3	± 0.6	± 1.0	± 2.0

Conditions/Horizontal supply pressure P=0.5MPa

Load weight Upper limit of allowable value

Solenoid valve for locking mounted on the locking pdr

Maximum value of stopping position dispersion from 100 measurements

Spring Lock Holding Power (Maximum static Load)

Bore size [mm]	32	40	50	63	80	100
Holding power [N]	552	882	1370	2160	3430	5390

Quick Reference
Guide

C55

C85

C76

CP95

C95

-X
(Made to Order)

D-
(Auto Switch)

Model Selection
Procedures

Series C95N

C95N Cylinder

Part No: Mounting Bracket, Mounting Accessories

Description	Bore size	ø32	ø40	ø50	ø63	ø80	ø100
L	Foot ⁽¹⁾	L5032	L5040	L5050	L5063	L5080	L5100
F,G	Flange	FN5032	FN5040	FN5050	FN5063	F5080	F5100
C	Single rear clevis	C5032	C5040	C5050	C5063	C5080	C5100
D	Double rear clevis	D5032	D5040	D5050	D5063	D5080	D5100
DS	Double rear clevis (for ES accessory)	DS5032	DS5040	DS5050	DS5063	DS5080	DS5100
ES	Angled rear clevis with ball joint	ES5032	ES5040	ES5050	ES5063	ES5080	ES5100
E	Angled rear clevis	E5032	E5040	E5050	E5063	E5080	E5100
C95-S	Trunnion pivot bracket	C95-S03	C95-S04	C95-S04	C95-S06	C95-S06	C95-S10
GKM	Rod clevis	GKM10-20	GKM12-24	GKM16_32	GKM16-32	GKM20-40	GKM20-40
KJ	Piston rod ball joint	KJ10D	KJ12D	KJ16D	KJ16D	KJ20D	KJ20D
JA	Floating joint	JA30-10-125	JA40-12-125	JA50-16-150	JA50-16-150	JAH50-20-150	JAH50-20-150

- Note 1) Two foot brackets required for one cylinder.
 Note 2) Accessories for each mounting bracket are as follows:Foot, Flange, Single clevis: Mounting bolts
 Double rear clevis: (D,DS): Clevis pin
 Note 3) C95-S: Set of 2 pcs.
 Note 4) GKM according to ISO 8140
 Note 5) KJ according to ISO 8139
 Note 6) Piston rod nut is standard

Single Rod Weight Table

Bore Size [mm]		32	40	50	63	80	100
Basic weight	Basic type B	1.40	2.15	3.53	5.18	8.99	12.72
	Trunnion T	0.15	0.26	0.34	0.57	1.03	1.71
Additional weight per 50mm of stroke	All mounting brackets	0.11	0.16	0.26	0.27	0.42	0.56

(Example) C95NDB32-100 (Standard, Ø32, 100er)
 •Basic weight..... 1.40 (basic type, Ø32)
 •Additional weight 0.11/50mm stroke
 •Cylinder stroke 100mm stroke
 $1.40 + 0.11 \times 100/50 = 3.02\text{kg}$

Manual override for unlocking

In case the air supply is cut off or discharged, unlocking can be performed with a commercially available tool. The fail safe mechanism locks again when manual override is released.

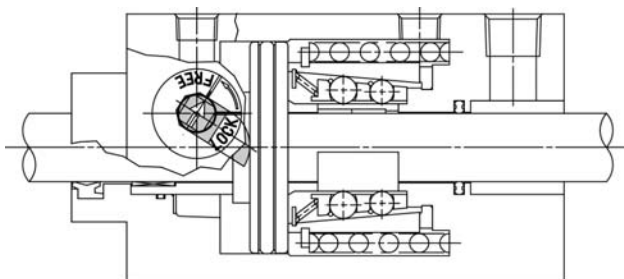

Weight accessories [kg]

Ø	32	40	50	63	80	100
L	0.16	0.20	0.38	0.46	0.89	1.09
F	0.20	0.23	0.47	0.58	1.30	1.81
C	0.16	0.23	0.37	0.60	1.07	1.73
D	0.20	0.32	0.45	0.71	1.28	2.11

Example:

Cylinder Ø40 mm, Stroke 100 mm, bracket D

$$\text{Weight} = 0.84 \text{ kg} + (0.16 \text{ kg} \times \frac{100}{50}) + 0.32 \text{ kg} = 1.48 \text{ kg}$$

Construction Principles

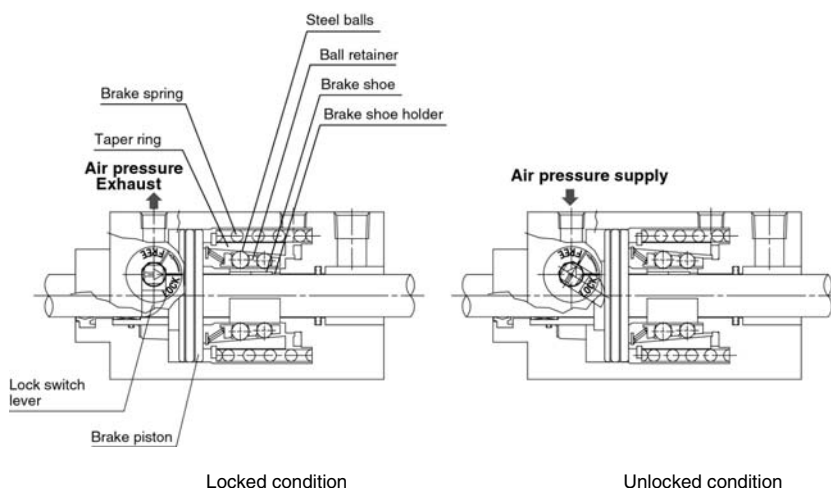

Spring lock (exhaust lock)

The spring force which acts upon the taper ring is magnified by a wedge effect, and is conveyed to all of the numerous steel balls which are arranged in two circles. These act on the brake shoe holder and brake, which locks the piston rod by tightening against it with a large force.

Unlocking is accomplished when air pressure is supplied to the unlocking port. The brake piston and taper ring oppose the spring force, moving to the right side, and the ball retainer strikes the cover section A. The braking force is released as the steel balls are removed from the taper ring by the ball retainer.

Construction

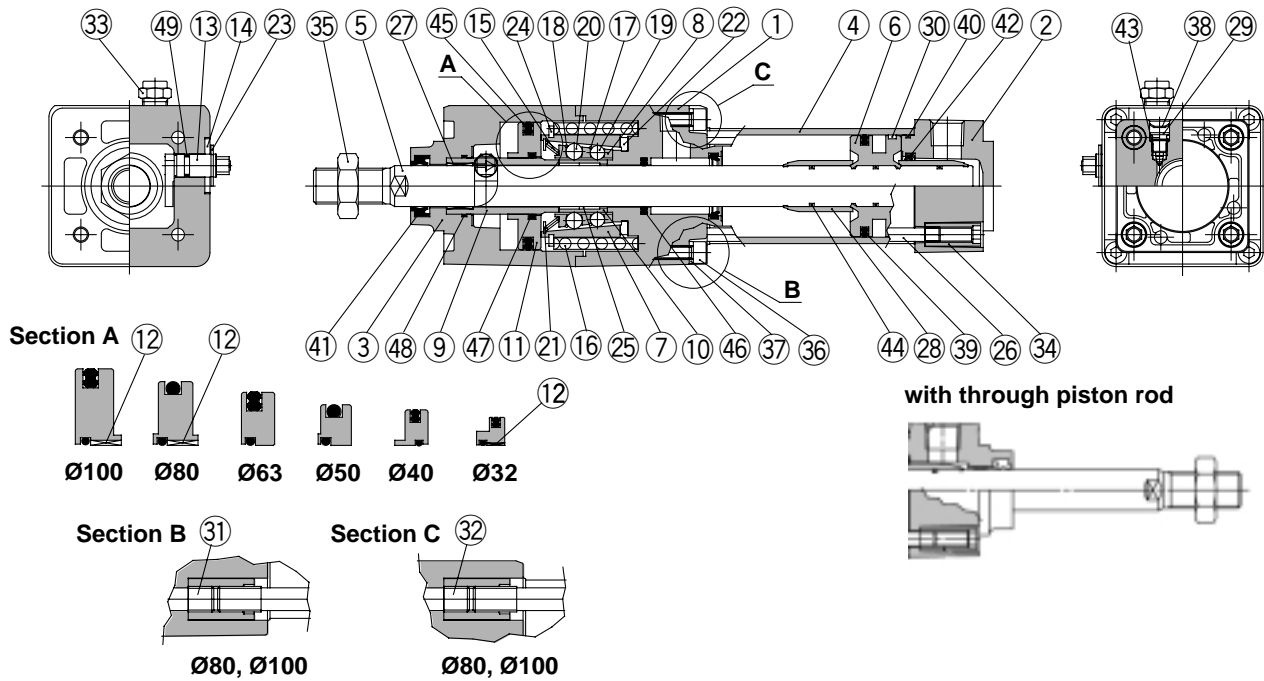

Parts list

No.	Description	Material	Note	
①	Rod cover	Aluminium alloy	Hard anodised & metallic coated	
②	Head cover	Aluminium alloy	Chromated & metallic coated	
③	Cover	Aluminium alloy	Hard anodised & metallic coated	
④	Cylinder tubing	Aluminium alloy	Hard anodised	
⑤	Piston rod	Carbon steel	Hard chrome plated	
⑥	Piston	Aluminium alloy	Chromated	
⑦	Taper Ring	Carbon steel	Heat treated	
⑧	Ball retainer	Special resin		
⑨	Piston guide	Carbon steel	Zinc chromated	
⑩	Brake shoe holder	Carbon steel	Heat treated	
⑪	Release piston	Ø40	Aluminium alloy Hard anodised	
		Ø50		
		Ø63		
		Ø32		Carbon steel Zinc chromated
		Ø80		
		Ø100		
⑫	Release piston bushing	Steel + special resin	Ø32, Ø80, Ø100 only	
⑬	Unlocking cam	Carbon steel	Glossy chromated	
⑭	Washer	Carbon steel	Black zinc chromated	
⑮	Retainer pre-load spring	Carbon steel	Zinc chromated	
⑯	Brake spring	Carbon steel	Zinc chromated	
⑰	Clip A	Stainless steel		
⑱	Clip B	Stainless steel		
⑲	Steel ball A	Carbon steel		
⑳	Steel ball B	Carbon steel		
㉑	Tooth ring	Stainless steel		
㉒	Damper	Polyurethane rubber		
㉓	C type retaining ring for unlocking cam shaft	Carbon steel		
㉔	C type retaining ring for taper ring	Carbon steel		
㉕	Brake shoe	Special friction material		
㉖	Tie rod	Carbon steel	Chromated	
㉗	Bushing	Lead-bronze casting		
㉘	Cushion ring	Brass		

Parts list

No.	Description	Material	Note
㉙	Cushion valve	Carbon steel	Nickel plated
㉚	Wear ring	PUR	
㉛	Unit holding tie-rod A	Carbon steel	Chromated Ø80, Ø100 only
㉜	Unit holding tie-rod B	Carbon steel	Chromated Ø80, Ø100 only
㉝	BC element		
㉞	Tie-rod nut	Carbon steel	Nickel plated
㉟	Rod end nut	Carbon steel	Nickel plated
㊱	Hexagon socket head cap screw	Carbon steel	Nickel plated Ø32, Ø63 only
㊲	Spring washer for hex. socket head cap screw	Carbon steel	Nickel plated Ø32, Ø63 only
㊳	Retaining ring	Carbon steel	
㊴	Piston seal	NBR	
㊵	Cylinder tube gasket	NBR	
㊶	Rod seal A	NBR	
㊷	Cushion seal	NBR	
㊸	Cushion valve seal	NBR	
㊹	Piston gasket	NBR	
㊺	Release piston gasket	NBR	
㊻	Rod seal B	NBR	
㊼	Release piston gasket	NBR	
㊽	Piston guide gasket	NBR	
㊾	Unlocking cam gasket	NBR	

Series C95N

Dimensions

Basic type (B)

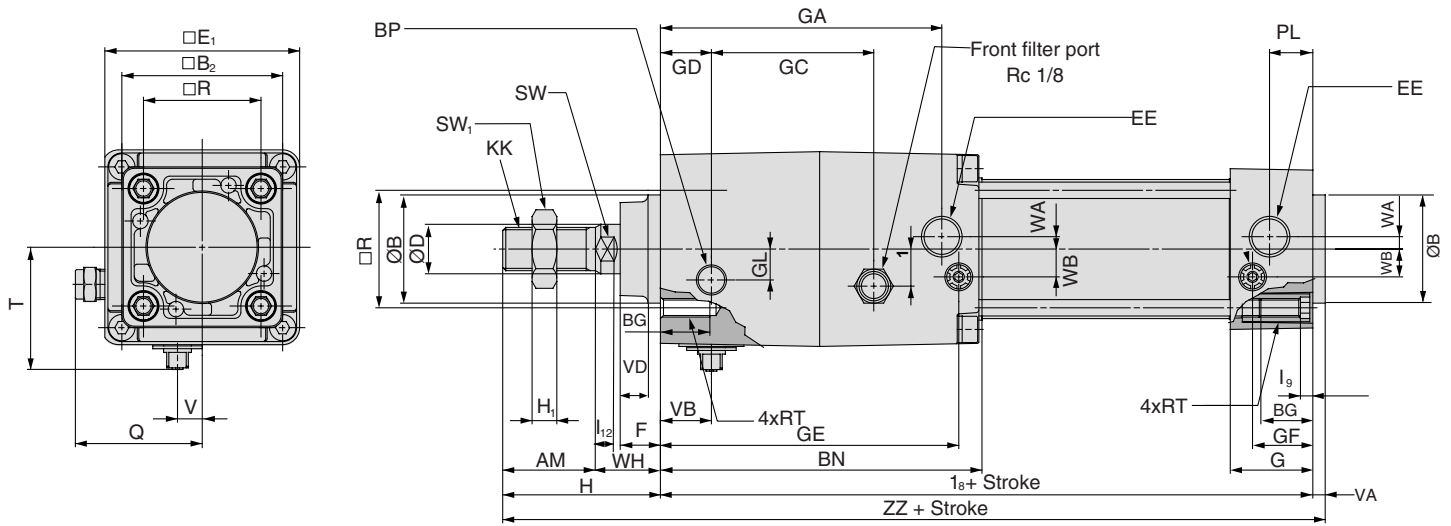

Bore size (mm)	AM	∅Be 11	□B ₂	BG	BN	BP	∅D	EE	□E	□E ₁	F	G	GA	GC	GD	GE	GF	GL	GL ₁	H	H ₁
32	22	30	46	16	97	G1/8	12	G1/8	46	54	13	27	83	45.5	13	88.5	18.3	7.5	12	48	6
40	24	35	52	16	104	G1/8	16	G1/4	52	63	13	27	91	52.5	16.5	96.5	19.5	10	12	54	8
50	32	40	65	16	120.5	G1/4	20	G1/4	65	75	14	31.5	104.5	58.5	19	111.2	22.4	11.5	15	69	11
63	32	45	75	16	134.5	G1/4	20	G3/8	75	90	14	31.5	119.5	68	23	123.5	20.7	17.5	12	69	11
80	40	45	95	16	169	G1/4	25	G3/8	95	102	20	38	150	81	33	157	26	22	18	86	13
100	40	55	114	16	189	G1/4	30	G1/2	114	116	20	38	170	96	37.5	177	26	25	20	91	16

Bore size (mm)	KK	I ₈	I ₉	I ₁₂	PL	Q	□R	RT	SW	SW ₁	T	V	VA	VB	VD	WA	WB	WH	ZZ
32	M10 x 1.25	164	4	6	13	37	32.5	M6	10	17	34	6.5	4	13	4	4	6.5	26	216
40	M12 x 1.25	182	4	6.5	14	41.5	38	M6	13	19	39.5	8	4	16.5	4	4	9	30	240
50	M16 x 1.5	195	5	8	15.5	47.5	46.5	M8	16	24	47	9	4	20	6	5	10.5	37	268
63	M16 x 1.5	224	5	8	16.5	55	56.5	M8	16	24	55.5	8.5	4	23	6	9	12	37	297
80	M20 x 1.5	259	5	10	19	61	72	M10	21	30	61.5	10.5	4	33	8	11.5	14	46	349
100	M20 x 1.5	289	5	10	19	68	89	M10	21	30	69.5	10.5	4	37.5	8	17	15	51	384

Dimensions

Double Rod (Option W)

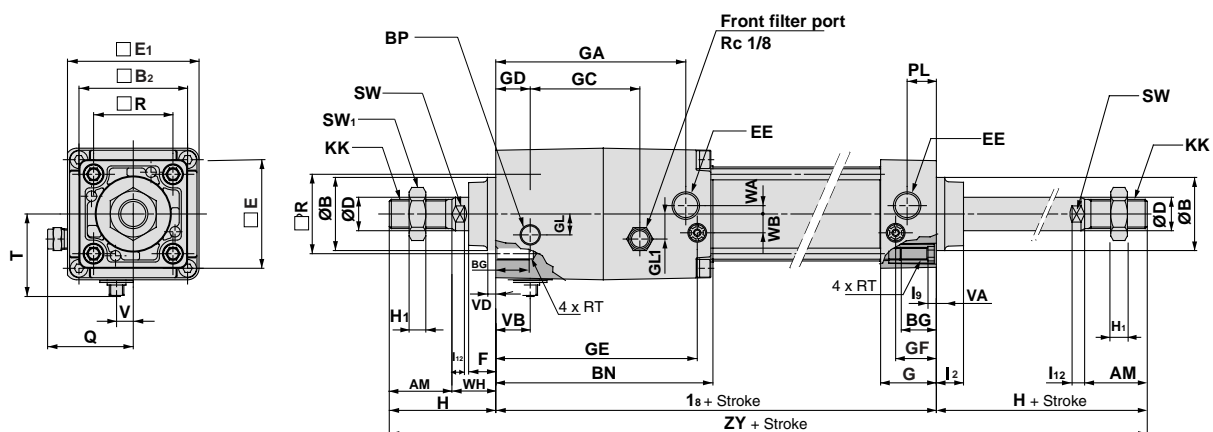

Bore size (mm)	AM	∅Be ₁₁	□B ₂	BG	BN	BP	∅D	EE	□E	□E ₁	F	G	GA	GC	GD	GE	GF	GL	GL ₁	H	H ₁
32	22	30	46	16	97	G1/8	12	G1/8	46	54	13	27	83	45.5	13	88.5	18.3	7.5	12	48	6
40	24	35	52	16	104	G1/8	16	G1/4	52	63	13	27	91	52.5	16.5	96.5	19.5	10	12	54	8
50	32	40	65	16	120.5	G1/4	20	G1/4	65	75	14	31.5	104.5	58.5	19	111.2	22.4	11.5	15	69	11
63	32	45	75	16	134.5	G1/4	20	G3/8	75	90	14	31.5	119.5	68	23	123.5	20.7	17.5	12	69	11
80	40	45	95	16	169	G1/4	25	G3/8	95	102	20	38	150	81	33	157	26	22	18	86	13
100	40	55	114	16	189	G1/4	30	G1/2	114	116	20	38	170	96	37.5	177	26	25	20	91	16

Bore size (mm)	KK	I ₂	I ₈	I ₉	I ₁₂	PL	Q	□R	RT	SW	SW ₁	T	V	VA	VB	VD	WA	WB	WH	ZY
32	M10 x 1.25	15	164	4	6	13	37	32.5	M6	10	17	34	6.5	4	13	4	4	6.5	26	260
40	M12 x 1.25	17	182	4	6.5	14	41.5	38	M6	13	19	39.5	8	4	16.5	4	4	9	30	290
50	M16 x 1.5	24	195	5	8	15.5	47.5	46.5	M8	16	24	47	9	4	20	6	5	10.5	37	333
63	M16 x 1.5	24	224	5	8	16.5	55	56.5	M8	16	24	55.5	8.5	4	23	6	9	12	37	362
80	M20 x 1.5	30	259	5	10	19	61	72	M10	21	30	61.5	10.5	4	33	8	11.5	14	46	431
100	M20 x 1.5	32	289	5	10	19	68	89	M10	21	30	69.5	10.5	4	37.5	8	17	15	51	471

Series C95N

Dimensions Brackets on Cylinder

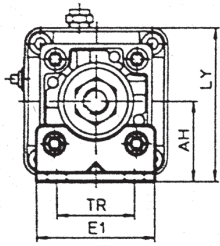

Axial Foot Type

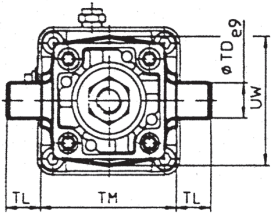
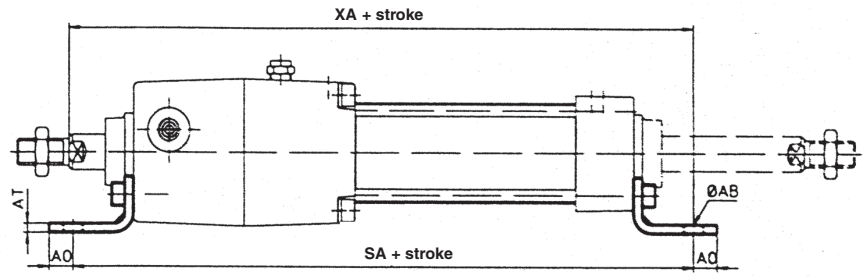

Trunion Type

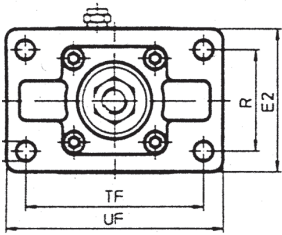
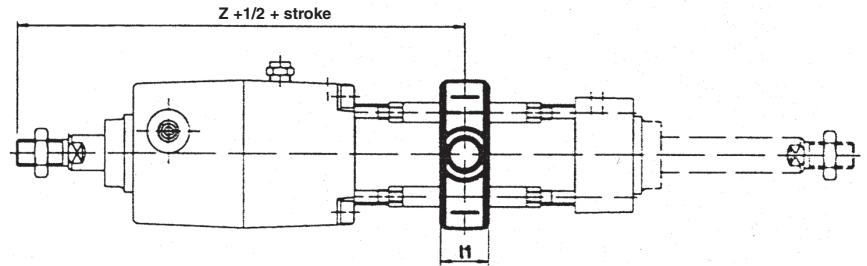

Rear Flange Type

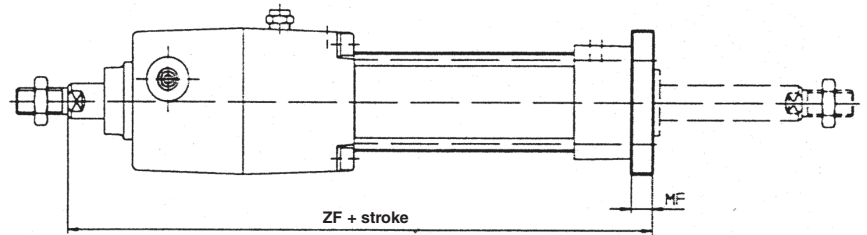

Front Flange Type

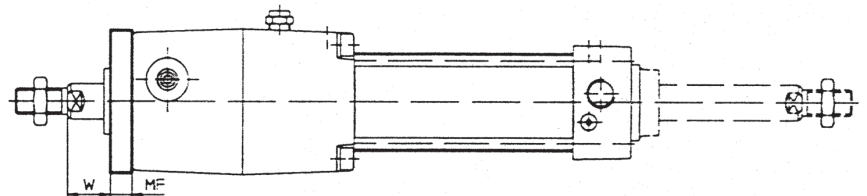

Single Clevis Type

Double Clevis Type

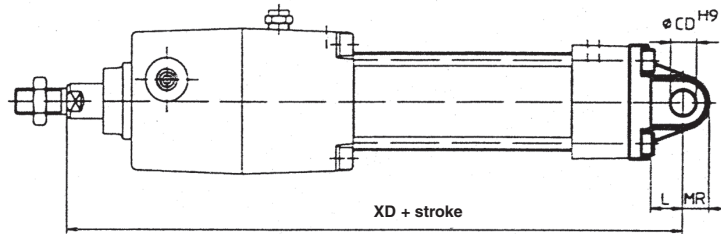
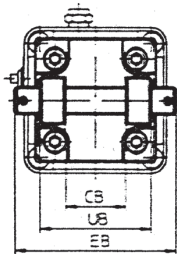
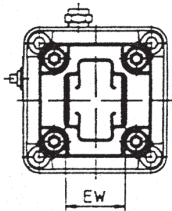

Bore size (mm)	Ø AB	AH	AD	AT	CB ₁	ØCD H9	E1	E2	EB	EW ₂	ØFB	L	LY	MF	MR	R	SA	ØTD e9	TF	TL	TM
32	7	32	10	4	26	10	48	56	65	26	7	12	59	10	9.5	38	212	12	72	12	50
40	9	36	11	4	28	12	55	65	75	28	9	15	67.5	10	12	46	238	16	83	16	63
50	9	45	12	5	32	12	68	77	80	32	9	15	82.5	12	12	45	259	16	90	16	75
63	9	50	12	5	40	16	80	92	90	40	9	20	95	12	16	62	288	20	115	20	90
80	12	63	14	6	50	16	100	100	110	50	12	20	114	16	16	63	341	20	126	20	110
100	14	71	16	6	60	20	120	120	140	60	14	25	129	16	20	75	371	25	150	25	132

1) +0.03/+0.1 2) -0.2/-0.6

Bore size (mm)	TR	UB	UF	UW	W	XA	XD	Z	ZF	I1
32	32	45	87	49	16	214	212	165	200	18
40	36	52	101	58	20	240	237	183.5	222	22
50	45	60	120	71	25	264	259	211	244	24
63	50	70	135	87	25	293	293	232.5	273	28
80	63	90	153	110	30	346	341	281	321	34
100	75	110	178	136	35	381	381	311	356	40



Series C95N Specific Product Precaution

Air Pressure Circuits

Warning

1. Basic Circuits

1. [Horizontal]

Forward

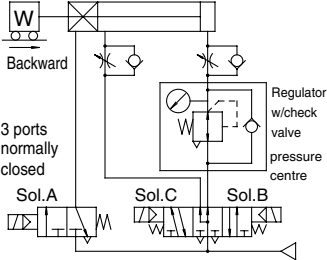

2. [Vertical]

[Load in direction of rod extension]

[Load in direction of rod retraction]

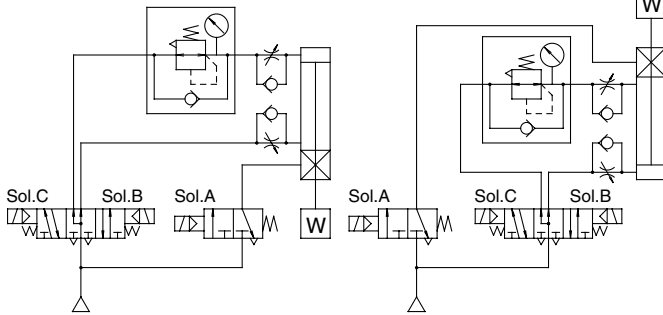

Caution

- A 3 position pressure centre solenoid valve and regulator with check valve can be replaced with two 3 port normally open valves and a regulator with relief function.

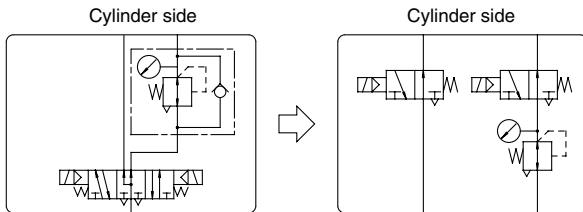

[Example]

1. [Horizontal]

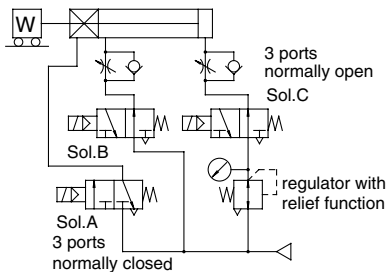

Air Pressure Circuits

Caution

2. [Vertical]

[load in direction of rod extension]

[Load in direction of rod retraction]

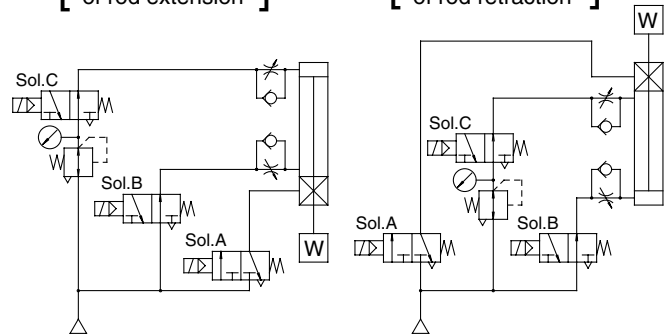

Manual Unlocking

Caution

- The unlocking cam provided on the C95N Series is an emergency unlocking mechanism only. During an emergency when the air supply is cut off, it is used to alleviate a problem by forcibly pushing the release piston back to release the lock. However, take note that the sliding resistance of the piston rod will be high compared to unlocking with air pressure.
- When installing into equipment or machinery, etc., in cases where it will be necessary to hold an unlocked condition for an extended time, air pressure of 0.25MPa or more should be applied to the unlocking port.
- Do not turn the unlocking cam (the arrow ← on the unlocking cam head) past the FREE position. If it is turned too far there is a danger of damaging the unlocking cam.

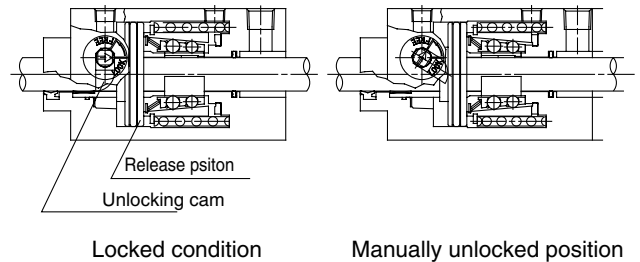

[Principle]

If the unlocking cam is turned counter clockwise with a tool such as an adjustable angle wrench, the release piston is pushed back and the lock is released. Since the lever will return to its original position when released and become locked again, it should be held in this position for as long as unlocking is needed.

Precautions on Model Selection

⚠ Caution

Example

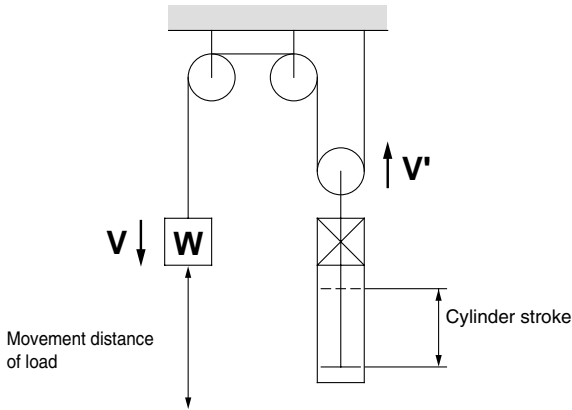

Selection Example

- **Load weight:** $m=50\text{kg}$
- **Movement distance:** Stroke=500mm
- **Movement time:** $t=2\text{s}$
- **Load condition:** Vertical downward=Load in direction of rod extension
- **Operating pressure:** $P=0.4\text{MPa}$

Step 1: From graph 1 find the maximum movement speed of the load
 \therefore Maximum speed V : approx 350mm/s

Step 2: Select graph 6 based upon the load condition and operating pressure, and then from the intersection of the maximum speed $V=350\text{mm/s}$ found in step 1, and the load weight $m=50\text{kg}$
 $\therefore \text{Ø63}$ →selecta C95NDB63 or larger bore size.

Step 1 Find the maximum load speed: V

Graph 1

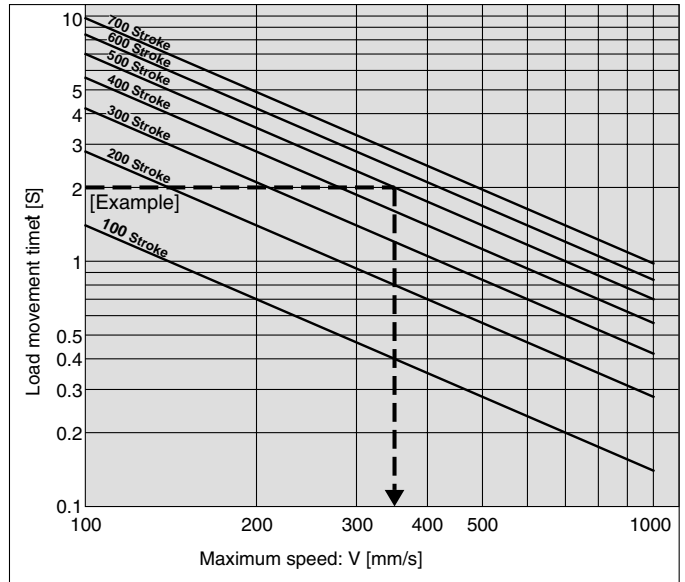

Step 2 Find the cylinder bore size

Load condition

Operating pressure

Direction of load at right angle to rod
 (* θ Being held by a guide)

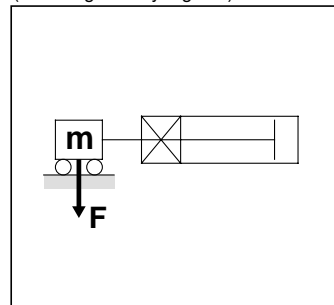

Load in direction of rod extension
 Load in direction of rod retraction

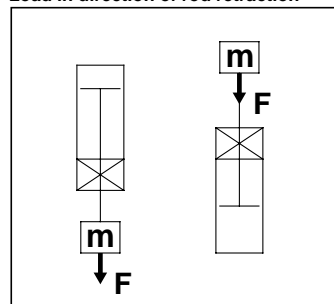

Selection Graphs

Graph 2

0.3MPa^a P<0.4MPa

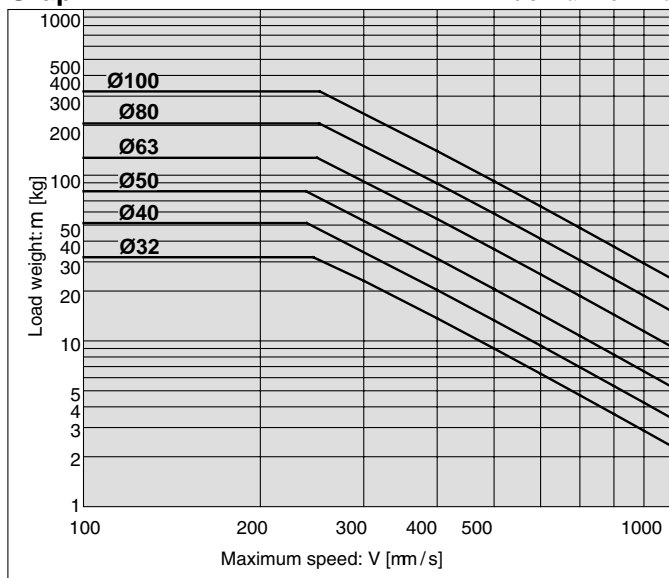

Graph 5

0.3MPa^a P<0.4MPa

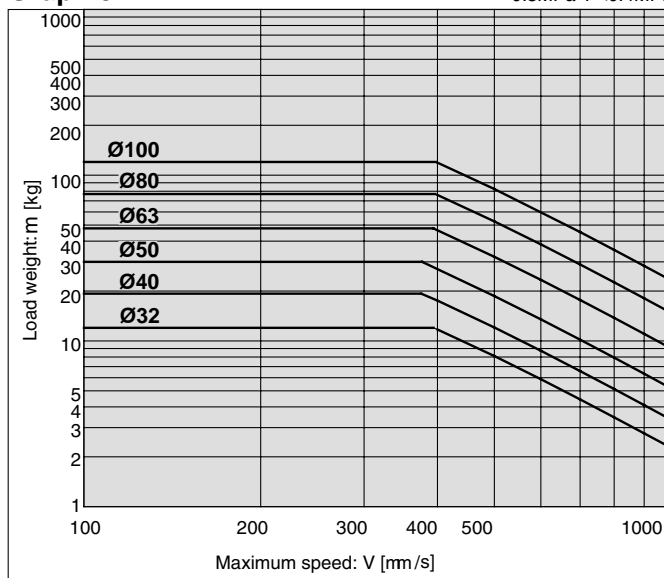

Graph 3

0.4MPa^a P<0.5MPa

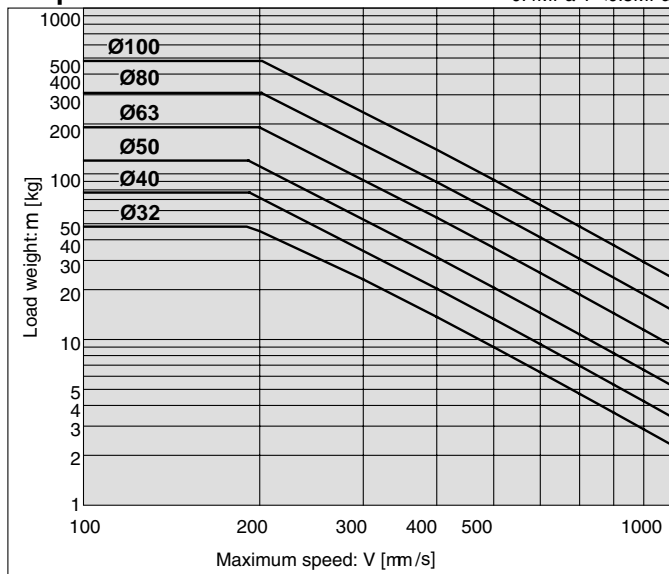

Graph 6

0.4MPa^a P<0.5MPa

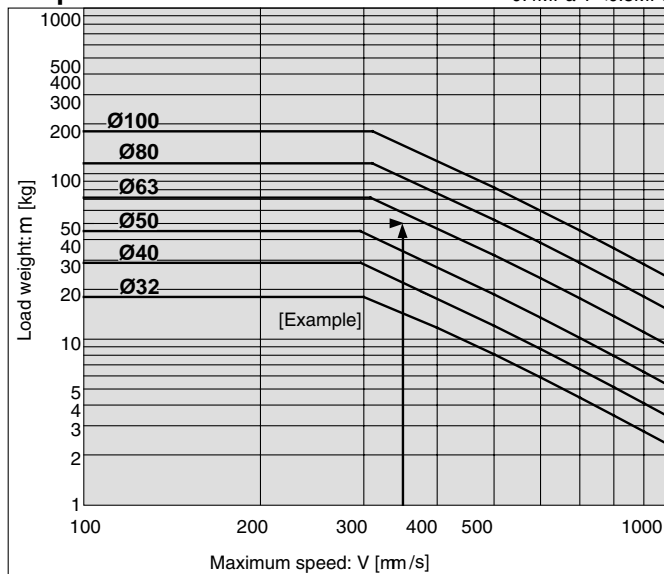

Graph 4

0.5MPa^a P

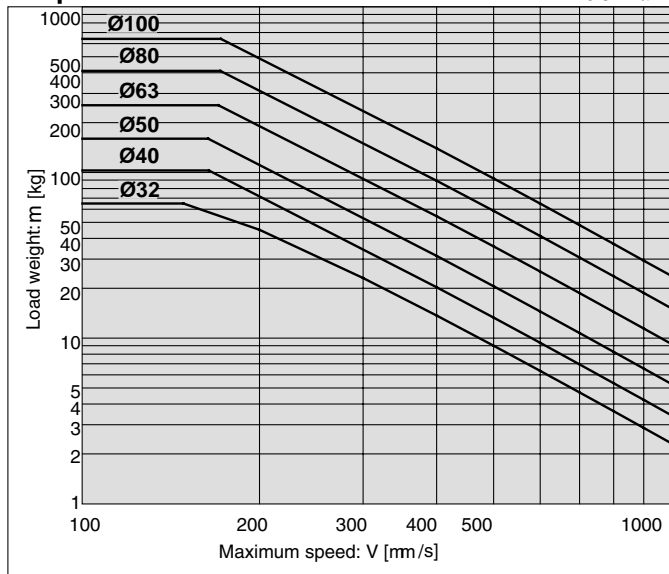

Graph 7

0.5MPa^a P

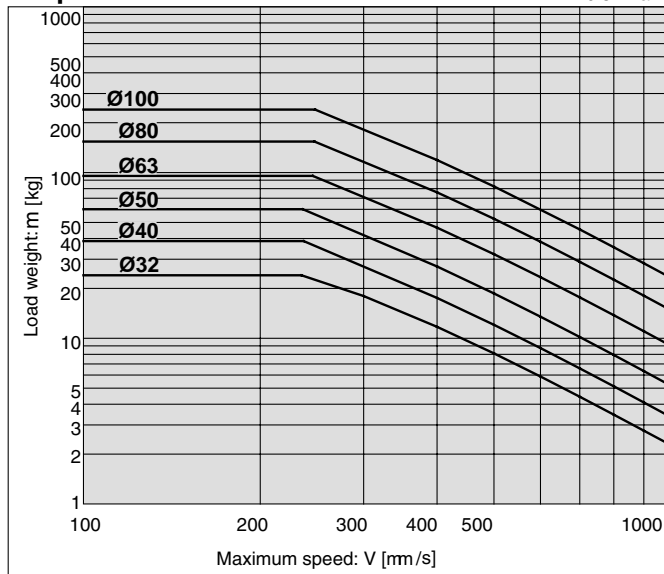

Quick Reference
Guide

C55

C85

C76

CP95

C95

-X
(Made to Order)

D-
(Auto Switch)

Model Selection
Procedures

Series C95 Auto Switch Specifications

Applicable Auto Switch



Style	Auto switch model	Electrical entry (function)
Reed switch	D-A5□/A6	Grommet
	D-A59W	Grommet (2 color indication)
Solid state switch	D-F5□/J5	Grommet
	D-F5□W/J59W	Grommet (2 color indication)
	D-F5BAL	Grommet (2 color indication, Water resistant)
	D-F5□F	Grommet (2 color indication, diagnostic output)
	D-F5NTL	Grommet (Timer)

Minimum Strokes for Auto Switch Mounting

Style	Auto switch model	No. of auto switches	Support bracket except center trunnion					Center trunnion						
			ø32	ø40	ø50	ø63	ø80	ø100	ø32	ø40	ø50	ø63	ø80	ø100
Reed switch	D-A5, D-A6	2 (On different faces or same face)	15					20	60	80	105	110	115	
		1	20					25	60	70	85	110	115	120
Solid state switch	D-F5/J5	2 (On different faces or same face)	15					25	60	70	85	110	115	120
		1	10					25	70	75	95	120	125	130
	D-F5□W D-J59W D-F5BAL D-F5□F D-F5LF	2 (On different faces or same face)	15					25	70	75	90	120	125	130
		1	10					25	70	75	90	120	125	130
		1	10					25	70	75	90	120	125 </tr	

Auto Switch Mounting Position and Mounting Height

Reed switch

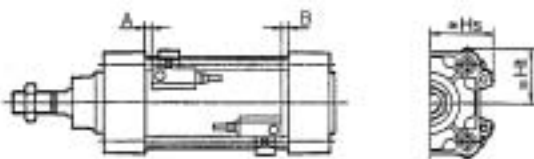

Solid state switch

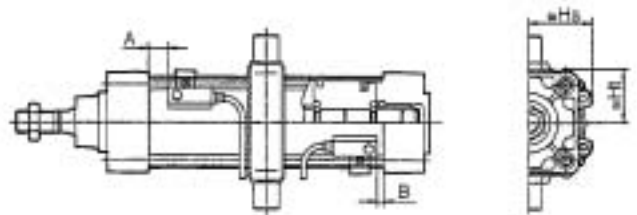

Auto Switch Mounting Position

Bore size (mm)	D-A5/D-A6		D-A59W		D-F5 D-J5		D-F5 W D-J59W D-F5BAL		D-F5NTL	
	A	B	A	B	A	B	A	B	A	B
ø32	10.5	0	14.5	2	17	4.5	21	8.5	22	9.5
ø40	21.5	0	25.5	2	28	4.5	32	8.5	33	9.5
ø50	23	0	27	2.5	29.5	5	33.5	9	34.5	10
ø63	28	0	32	2.5	34.5	5	38.5	9	39.5	10
ø80	28	2.5	22	6.5	24.5	9	28.5	13	29.5	14
ø100	28	2.5	32	6.5	34.5	9	38.5	13	39.5	14

Auto Switch Mounting Height

Bore size (mm)	D-A5 D-A6 D-A59W		D-F5, D-J5 D-F5 W, D-J59W D-F5BAL, D-F5NTL	
	Ht	Hs	Ht	Hs
ø32	24.5	35	25	32.5
ø40	27.5	38.5	27.5	36.5
ø50	34.5	43.5	34	41
ø63	39.5	48.5	39	46
ø80	46.5	55	46.5	52.5
ø100	55	62	55	59.5

Direct mount auto switches can be installed on tie-rod type cylinders

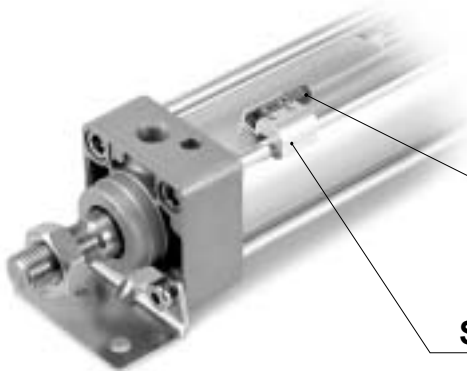

Direct mount type auto switch

Reed: D-Z7 Solid state: D-Y5
 D-Z8 D-Y6
 D-Y7

Switch mounting bracket

Direct mount type auto switches can now be attached to the tie-rods by using a special switch mounting bracket.

Smaller size

Protrusion of auto switches has been reduced

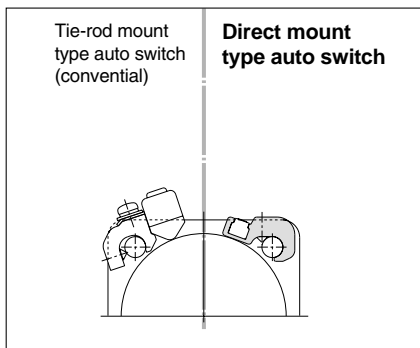

Easier handling

Auto switch mounting and positioning can be performed from one direction

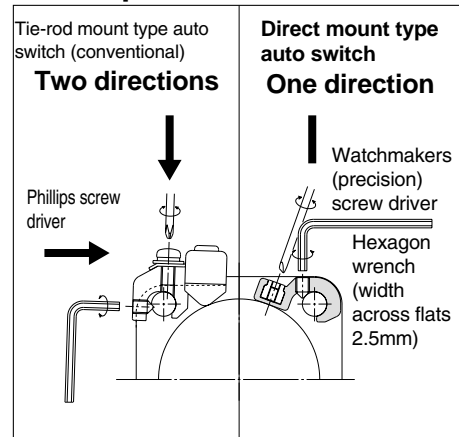

Auto Switch Mounting Bracket for D-M9□

Bore size (mm)	Order No.
ø32, ø40	BMB5-032
ø50, ø63	BA7-040
ø80, ø100	BA7-063

Switch Mounting Bracket Models

Bore size [mm]	Mounting bracket model	Accessory	Auto switch
32, 40	BMB4-032	Screw (M4 x 6L) 2 pcs.	Reed-Switch D-Z7 D-Z80
50, 63	BMB4-050		Solid state D-Y5 D-Y6 D-Y7
80, 100	BA4-063		

Applicable Auto Switches

auto switch models		Model	Special function	Electrical Entry	Indicator light	Wiring (output)	Load voltage		Lead wire length [m]			Applicable loads				
Vertical	In-line						DC	AC	0.5 (-)	3 (L)	5 (Z)					
—	Z76	Reed-Switch	—	Grommet	Yes	3-wire	—	5V	—	●	●	—	IC	—		
—	Z73					2-wire	24V	12V	100V	●	●	●	—		—	Relay, PLC
—	Z80					2-wire	5V, 12V	100V	●	●	—	—	—		—	—
Y69A	Y59A	Solid state Switch	—	Grommet	Yes	3-wire (NPN)	24V	5V	—	●	●	○	IC	Relay, PLC		
Y7PV	Y7P					3-wire (PNP)		12V		●	●	○	—			
Y69B	Y59B					2-wire		12V		●	●	○	—			
Y7NWV	Y7NW					3-wire (NPN)		5V		●	●	○	IC			
Y7PWV	Y7PW					3-wire (PNP)		12V		●	●	○	—			
Y7BWV	Y7BW					2-wire		12V		●	●	○	—			
—	Y7BA					Water resistant (2-colour indicator)		—		—	—	—	—		—	—
M9NV	M9N	Solid state Switch	—	Connector and Grommet	Yes	3 wire (NPN)	24V	5V, 12V	—	●	●	○	IC circuit	Relay PLC		
M9PV	M9P					3 wire (PNP)		12V		●	●	○				
M9BV	M9B					2 wire		12V		●	●	○				

* Lead wire length 0.5m..... — (Example: A53)
 3m..... L (Example: A53L)
 5m..... Z (Example: A53Z)

○: Manufactured upon receipt of order.

Series C95

Auto Switches

How to install auto switches

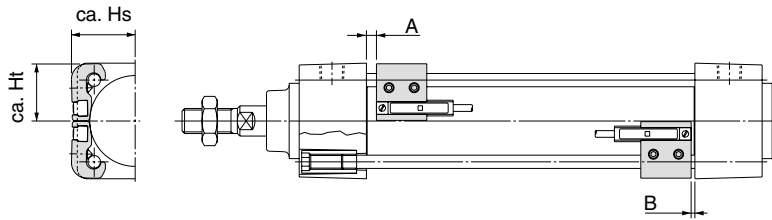

Auto Switch mounting positions and dimensions [mm]

Bore Size [mm]	All models		D-Z7/Z8, D-Y5/Y7 (W)		D-Y6, D-Y7 (W) V		D-Y7BA	
	A	B	Hs	Ht	Hs	Ht	Hs	Ht
32	14	1.5	25.5	23	26.5	23	30	23
40	25	1.5	29.5	26	30	26	34	26
50	26.5	2	33.5	31	34.5	31	38	31
63	31.5	2	39	36	40	36	43	36
80	31.5	6	47.5	45	48.5	45	52	45
100	31.5	6	55.5	53.5	56.5	53.5	60	53.5

Auto switch operating ranges [mm]

Bore Size [mm]	D-Z7 D-Z8	D-Y5/Y7 (W) D-Y6/Y7 (W) V	D-Y7BA
32	7.5	5.5	3.5
40	8.5	5.5	3.5
50	7.5	7	3.5
63	9.5	7.5	4
80	9.5	6.5	4.5
100	10.5	5.5	5

Note) This is a standard including hysteresis, and is not guaranteed. (variations as much as 30%)
There may be large changes depending on the ambient environment.

Minimum length [mm]

Auto Switch	with bracket T					
	Ø32	Ø40	Ø50	Ø63	Ø80	Ø100
D-Z7/Z8, D-Y5/Y7 (W)	80	85	90	90	95	100
D-Y6/Y7 (W) V	60	85	65	70	75	85
D-Y7BA	55	90	90	100	105	110

Mounting and Movement of Auto Switches

Caution!

When tightening the auto switch mounting screw, use a watchmakers screw driver with a handle diameter of about 5 to 6mm.

Furthermore, use a tightening torque of 0.05 to 0.1 Nm. As a rule, it should be turned about 90° from the point at which tightening can be felt. Use a tightening torque of 1 to 1.2 Nm for the hexagon socket head set screws (M4 x 0.7).

1. Place the mounting bracket on the cylinder tie-rod, and secure it in the detection position with the set screw so that the bottom of the mounting bracket makes firm contact with the cylinder tube. (Use a hexagon wrench)
2. Insert an auto switch into the switch mounting groove of the mounting bracket, and place it in the approximate auto switch mounting position.
3. After confirming the detection position, secure the auto switch by tightening the mounting screw which is included with it.
4. Return to step 2 to change the detection position.

Note) In order to protect the auto switch, install it so that its body is housed at least 15mm inside the switch mounting groove.

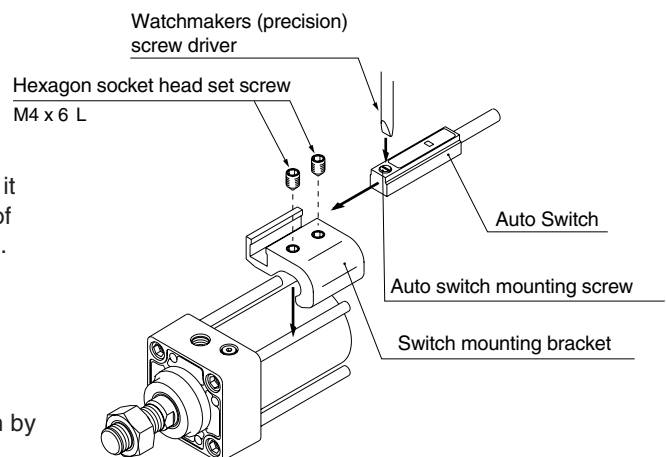



Series C95 Specific Product Precautions

Adjustment

⚠ Warning

- ① **Do not open the cushion valve above the stopper.**
Cushion valves are provided with a crimp ($\phi 32$) or a retaining ring ($\phi 40$ to $\phi 100$) as a stopping mechanism, and the cushion valve should not be opened above that point.
If air is supplied and operation started without confirming the above condition, the cushion valve may be ejected from the cover.

Bore size (mm)	Cushion valve	Width across flats	Socket wrench
32, 40, 50	MB-32-10-C1247	2.5	JIS 4648 Hex spanner wrench 2.5
63, 80, 100	MB-63-10-C1250	4	JIS 4648 Hex spanner wrench 4

- ② **When replacing brackets, use the hexagon wrenches shown below.**

Bore size (mm)		Bolt	Width across flats	Tightening torque (Nm)
32, 40		MB-32-48-C1247	4	4.9
50, 63		MB-50-48-C1249	5	11
80, 100	Foot	MB-80-48AC1251	6	25
	Others	MB-80-48BC1251		

With Non-rotating Rod (Double Acting: Single Rod)

Operating Precautions

⚠ Caution

- ① **Do not apply more than the allowable rotating torque to the piston rod.**
If more than the allowable rotating torque is applied, the non-rotating guide will be deformed and there will be a significant loss of rotational accuracy. This may cause damage to the machinery.

Mounting & Piping

⚠ Caution

- ① **Mounting of a work piece at the rod end.**
When screwing a fitting or nut, etc. onto the threads at the end of the piston rod, push the piston rod into its fully retracted position, and grasp the protruding section with a wrench.
Furthermore, when tightening, take care that the torque is not applied to the non-rotating guide.

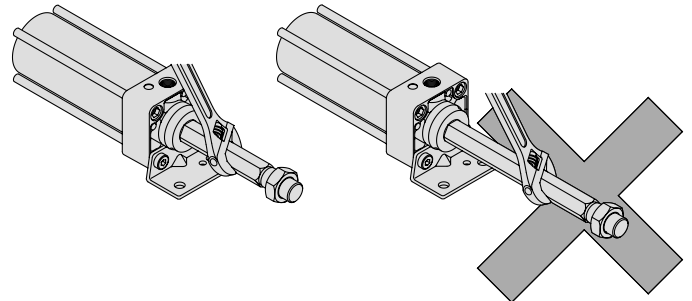

ISO/VDMA Cylinder: Large Bore Size Type

Series C95

ø160, ø200, ø250

Conforming to ISO 6431/CETOP RP43P/VDMA 24562

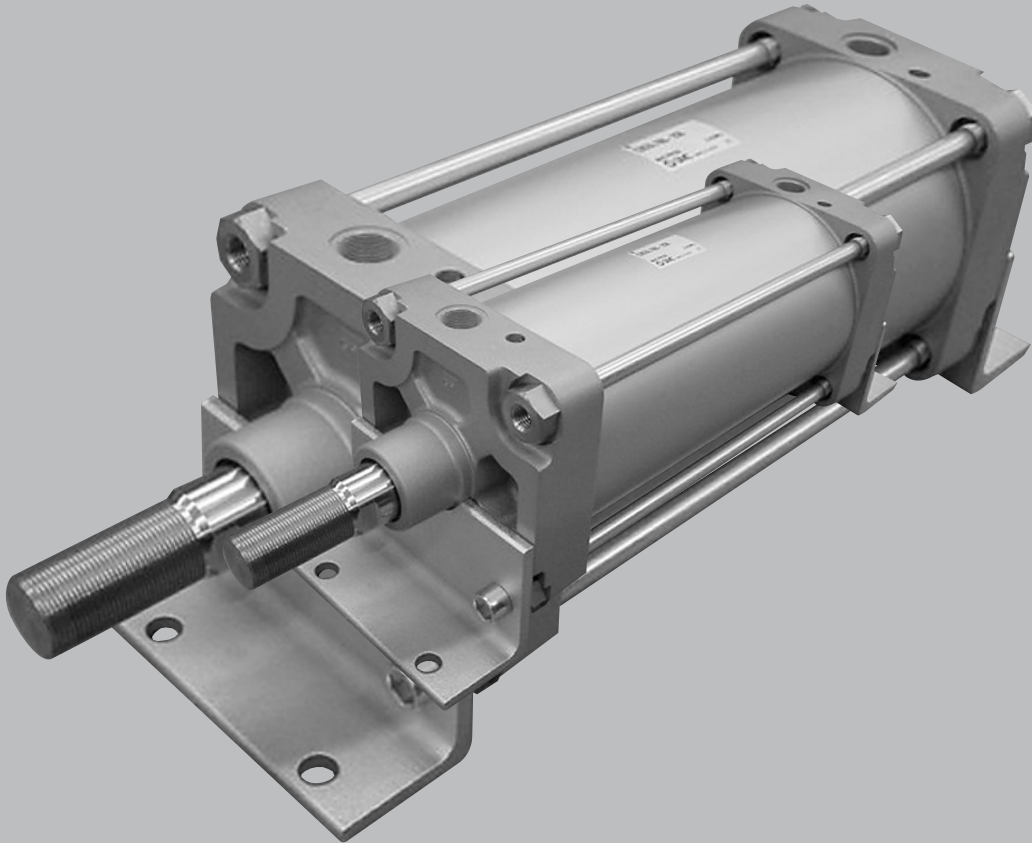

Series Variations

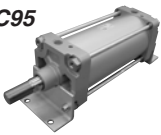
Series	Action	Type	Basic	Standard variations	Option	Bore (mm)	Page
				Built-in magnet Stainless steel rod	Heat resistant		
Large Bore Size Series C95 	Double acting	Single rod	•	•	•	160 200 250	6-38

Quick Reference
Guide

C55

C85

C76

CP95

C95

-X
(Made to Order)

D-
(Auto Switch)

Model Selection
Procedures

ISO/VDMA Cylinder: Large Bore Size Type Double Acting, Single Rod

Series C95

ø160, ø200, ø250

How to Order

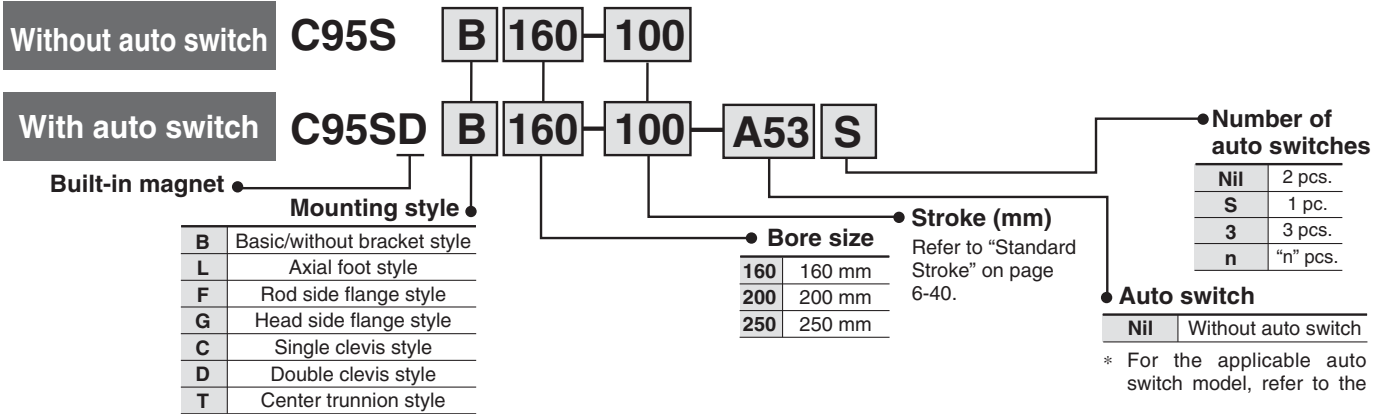

Applicable Auto Switch/Tie-rod Mounting

Type	Special function	Electrical entry	Indicator light	Wiring (Output)	Load voltage		Auto switch model		Lead wire length (m)			Applicable load				
					DC	AC	Tie-rod mounting	Band mounting	0.5 (Nil)	3 (L)	5 (Z)					
Reed switch	—	Grommet	Yes	3-wire (Equiv. to NPN)	—	5 V	—	A56	—	●	●	—	IC			
				2-wire	24 V	12 V	—	A53	—	●	●	●	—	Relay, PLC		
						5 V, 12 V	100 V, 200 V	A54	—	●	●	●	—			
						12 V	200 V or less	A67	—	●	●	—	IC			
				Diagnostic indication (2-color)	Terminal conduit	No	—	—	—	A59W	—	●	●	—	—	
	3-wire	—	5 V				—	Z76	—	●	●	—	IC			
	—	DIN terminal	Yes	2-wire	24 V	12 V	AC 100	Z73	—	●	●	●	—	Relay, PLC		
						5 V, 12 V	100 V or less	Z80	—	●	●	—	IC			
						12 V	—	—	A33	—	—	—	—	—	PLC	
						100 V, 200 V	—	—	A34	—	—	—	—	—	Relay, PLC	
—						—	—	A44	—	—	—	—	—	—		
Solid state switch	—	Grommet	Yes	3-wire (NPN)	24 V	5 V, 12 V	—	F59	—	●	●	○	IC			
				3-wire (PNP)				F5P	—	●	●	○				
				2-wire	—	12 V	100 V, 200 V	J51	—	●	●	○	—			
								J59	—	●	●	○				
				Diagnostic indication (2-color)	Grommet	Yes	3-wire (NPN)	24 V	5 V, 12 V	—	F59W	—	●	●	○	IC
							3-wire (PNP)				F5PW	—	●	●	○	
				Water resistant (2-color)	Grommet	Yes	2-wire	24 V	12 V	—	J59W	—	●	●	○	—
							3-wire (NPN)				F5BAL	—	—	●	○	
				With timer	Grommet	Yes	3-wire (NPN)	24 V	5 V, 12 V	—	F5NTL	—	—	●	○	IC
							4-wire (NPN)				F59F	—	●	●	○	
	Diagnostic output (2-color)	Grommet	Yes	3-wire (NPN)	24 V	5 V, 12 V	—	Y59A	—	●	●	○	IC			
				2-wire				Y59B	—	●	●	○				
	—	Grommet	Yes	3-wire (PNP)	24 V	12 V	—	Y7P	—	●	●	○	—			
				3-wire (NPN)				Y7NW	—	●	●	○				
	Diagnostic indication (2-color)	Grommet	Yes	3-wire (PNP)	24 V	5 V, 12 V	—	Y7PW	—	●	●	○	IC			
				3-wire (NPN)				Y7BW	—	●	●	○				
	Water resistant (2-color)	Grommet	Yes	2-wire	24 V	12 V	—	Y7BAL	—	—	●	○	—			
				3-wire (NPN)				—	—	—	—	—		—	—	—
—	Terminal conduit	Yes	2-wire	24 V	12 V	—	G39	—	—	—	—	IC				
			3-wire (NPN)				K39	—	—	—	—	—	—	—		
—	Grommet	Yes	3 wire (NPN)	24 V	5 V, 12 V	—	M9NV	M9N	●	●	○	IC				
			3 wire (PNP)				M9PV	M9P	●	●	○					
			2 wire				M9BV	M9B	●	●	○					

* Lead wire length symbols: 0.5 m Nil (Example) A53
 3 m L (Example) A53L
 5 m Z (Example) A53Z

○: Manufactured upon receipt of order.
 Note) Switch can not be mounted on ø250

Mounting Bracket Part No.

Bore size (mm)	160	200	250
Foot ⁽¹⁾	L5160	L5200	L5250
Flange	F5160	F5200	F5250
Single clevis	C5160	C5200	C5250
Double clevis	D5160	D5200	D5250

Note 1) Two foot brackets and mounting bolts (4 pieces) are included in this no. (ø160 to ø250)

Note 2) Accessories for mounting brackets are as follows

Foot, Flange, Single clevis: Mounting bolts

Double clevis : Clevis pin, Retaining rings, Mounting bolts

Auto Switch Mounting Bracket Part No.

Bore size (mm)	160	200	250
D-A3/A4/K3/G3	BS1-160	BS1-200	—
D-A5/A6/F5/J5	BT-16	BT-16	BT-20
D-Z□/Y□	BS4-160	BS4-160	—
D-M9□	BS5-160	BS5-160	—

Accessory

Mounting Accessory, Cylinder

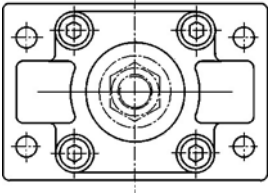
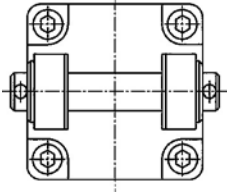
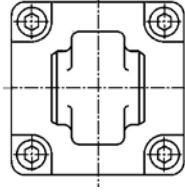
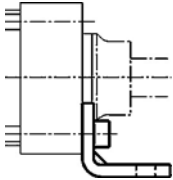
	F Rod/Head side flange	D Female head side clevis (Corresponds to E accessories)	C Male head side clevis
Bore size (mm)			
	Supplied with 4 screws	Supplied with bolt, safety device and 4 screws	Supplied with 4 screws
160 200 250	F5160 F5200 F5250	D5160 D5200 D5250	C5160 C5200 C5250
	See page 6-43 for dimensions.	See page 6-43 for dimensions	See page 6-44 for dimensions.
	L Foot		
Bore size (mm)			
	Supplied with two pieces Supplied with 4 screws		
160 200 250	L5160 L5200 L5250		
	See page 6-43 for dimensions.		

Mounting Accessory, Rod

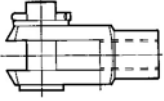
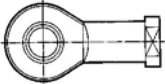
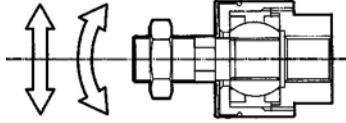
	GKM Rod clevis ISO 8140	KJ Piston rod ball joint ISO 8139	JA Floating joint
Bore size (mm)			
	Supplied with bolts and safety devices		
160 200 250	GKM35-54 GKM35-54 GKM40-84	KJ36D KJ36D KJ42D	JA160-36-200 JA160-36-200
	See page 6-45 for dimensions.	See page 6-45 for dimensions.	See page 6-45 for dimensions.

Series C95

Specifications

Bore size (mm)	160	200	250
Action	Double acting		
Fluid	Air		
Proof pressure	1.5 MPa		
Max. operating pressure	1.0 MPa		
Min. operating pressure	0.05 MPa		
Ambient and fluid temperature	Without auto switch: -10 to 70°C (No freezing) With auto switch: -10 to 60°C (No freezing)		
Lubrication	Not required (Non-lube)		
Operating piston speed	50 to 500 mm/sec		
Allowable stroke tolerance	Up to 250: $^{+1.0}_0$, 251 to 1000: $^{+1.4}_0$, 1001 to 1500: $^{+1.8}_0$		
Cushion	Both ends (Air cushion)		
Thread tolerance	JIS Class 2		
Port size	G 3/4		G 1
Mounting	Basic style, Axial foot style, Rod side flange style, Head side flange style, Single clevis style, Double clevis style, Center trunnion style		

JIS Symbol

Double acting

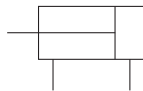

Minimum Stroke for Auto Switch Mounting

Refer to page 12 for "Minimum Stroke for Auto Switch Mounting".

Standard Stroke

Bore size (mm)	Max. * stroke
160	1600
200	2000
250	2400

Intermediate strokes are available.
* Please consult with SMC for longer strokes.

Theoretical Output

Bore size (mm)	Rod diameter (mm)	Operating direction	Piston area (mm ²)	Operating pressure (MPa)								
				0.2	0.3	0.4	0.5	0.6	0.7	0.8	0.9	1.0
160	40	OUT	20106	4021	6032	8042	10053	12064	14074	16085	18095	20106
		IN	18850	3770	5655	7540	9425	11310	13195	15080	16965	18850
200	40	OUT	31416	6283	9425	12566	15708	18850	21991	25133	28274	31416
		IN	30159	6032	9048	12064	15080	18095	21111	24127	27143	30159
250	50	OUT	49087	9817	14726	19635	24544	29452	34361	39270	44178	49087
		IN	47124	9425	14137	18850	23562	28274	32987	37699	42412	47124

Note) Theoretical force (N) = Pressure (MPa) x Piston area (mm²)

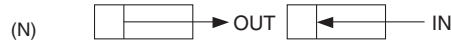

Weight/Aluminum Tube

Bore size (mm)		160	200	250	(kg)
Basic weight	Basic style	14.54	20.20	37.17	
	Foot style	4.90	7.76	15.00	
	Flange style	2.45	11.75	20.29	
	Single clevis style	6.90	9.10	18.60	
	Double clevis style	6.30	9.25	18.46	
	Trunnion style	4.50	7.23	14.40	
Additional weight per each 50 mm of stroke	All mounting brackets	0.83	0.90	1.60	
Accessory	Single rod clevis	1.62	1.62	2.76	
	Double clevis (With pin)	3.92	3.92	6.69	

Calculation: (Example) CP95SD160-100

- Basic weight 14.54 (kg) (Basic, ø160)
 - Mounting 6.30 (kg) (Double clevis)
 - Additional weight ... 0.83 (kg/50 st)
 - Cylinder stroke 100 (st)
- 14.54 + 0.83 x 100 50 + 6.30 = 22.50 kg

Allowable Kinetic Energy

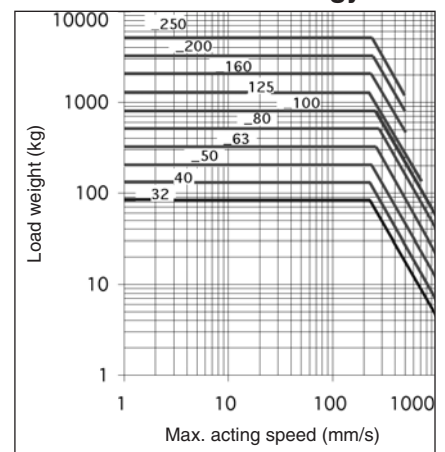

Example: Load limit at rod end when air cylinder ø200 is actuated with max. actuating speed 500 mm/s. See the intersection of lateral axis 500 mm/s and ø200 line, and extend the intersection to left. Thus the allowable load is 800 kg.

Construction

[First angle projection]

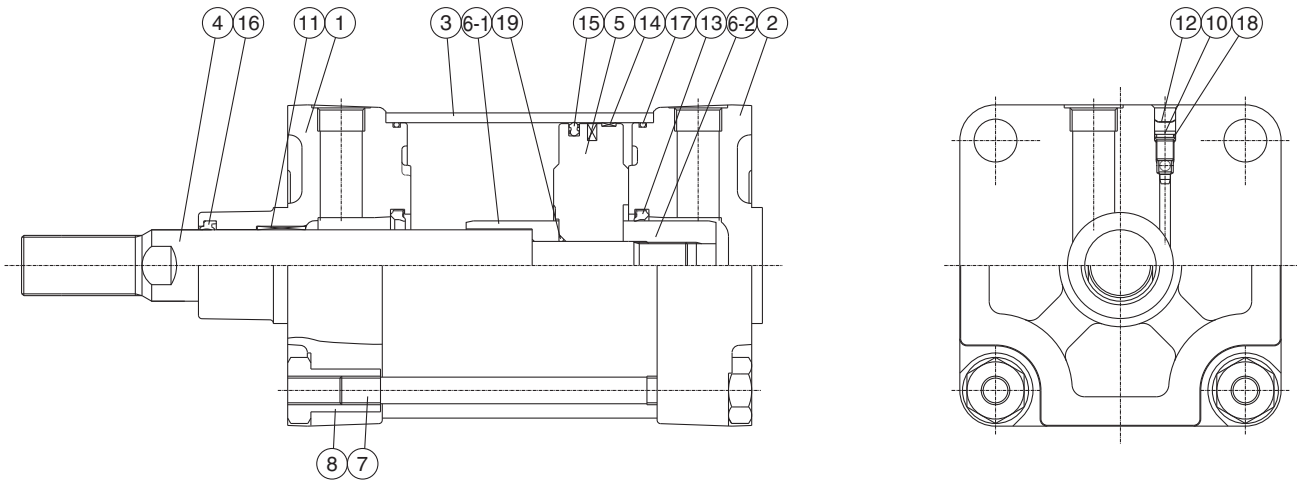

Component Parts

No.	Description	Material	Qty.	Note
①	Rod cover	Aluminum casted	1	
②	Head cover	Aluminum casted	1	
③	Cylinder tube	Aluminum alloy	1	
④	Piston rod	Carbon steel	1	
⑤	Piston	Aluminum alloy	1	
⑥	Cushion ring A	Rolled steel	1	
⑥	Cushion ring B	Rolled steel	1	
⑦	Tie-rod	Carbon steel	4	
⑧	Tie-rod nut	Steel	8	
⑩	Cushion valve	Steel wire	2	
⑪	Bushing	Lead-bronze casted	1	
⑫	Snap ring	Steel for spring	2	
⑬	Cushion seal	Urethane	2	
⑭	Wear ring	Resin	1	
⑮	Piston seal	NBR	1	
⑯	Rod seal	NBR	1	
⑰	Cylinder tube gasket	NBR	2	
⑱	Cushion valve seal	NBR	2	
⑲	Piston gasket	NBR	1	
⑳	Magnet ring		1	

Replacement Parts: Seal Kit

Bore size (mm)	Kit no.	Contents
160	CS95-160	Kits include items ⑬ to ⑰ from the table above.
200	CS95-200	
250	CS95-250	

* Seal kits consist of items ⑬ to ⑰ contained in one kit, and can be ordered using the order number for each respective tube bore size.

Quick Reference Guide
C55
C85
C76
CP95
C95
-X (Made to Order)
D- (Auto Switch)
Model Selection Procedures

Series C95

Dimensions: Without Mounting Bracket

[First angle projection]

C95SB Bore size - Stroke

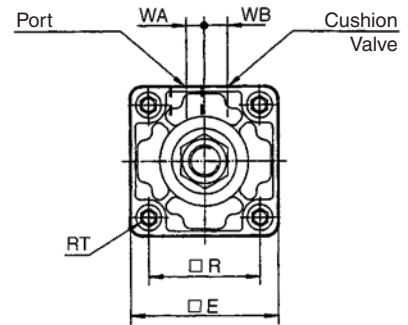
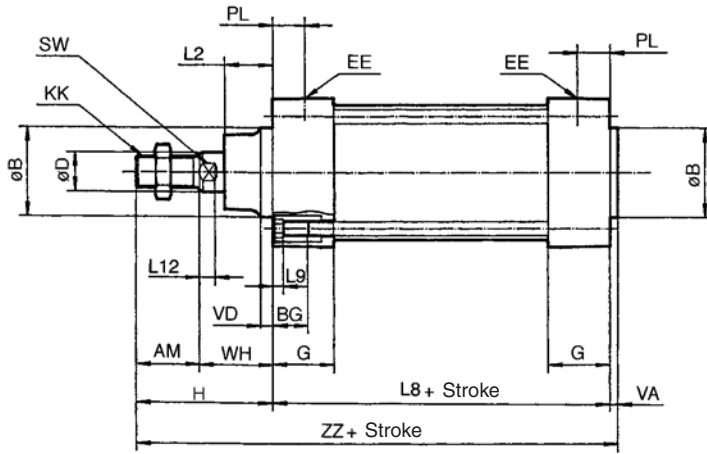

Bore size (mm)	AM	ϕB e11	ϕD	EE	PL	RT	L12	KK	SW	G	BG (Min.)	L8	VD	VA	WA	WB	WH	ZZ	$\square E$	$\square R$	L2	L9
160	72	65	40	G 3/4	30	M16 x 2	15	M36 x 2	36	55	27	180	8	6	15	25	80	338	180	140	50	0
200	72	75	40	G 3/4	35	M16 x 2	15	M36 x 2	36	57	27	180	15	6	18	25	95	353	220	175	55	0
250	84	90	50	G 1	31	M20 x 2.5	20	M42 x 2	46	59	29	200	20	10	20	28	105	399	270	220	65	0

Dimensions: Cylinder Mounting Accessory

[First angle projection]

Foot style (L)

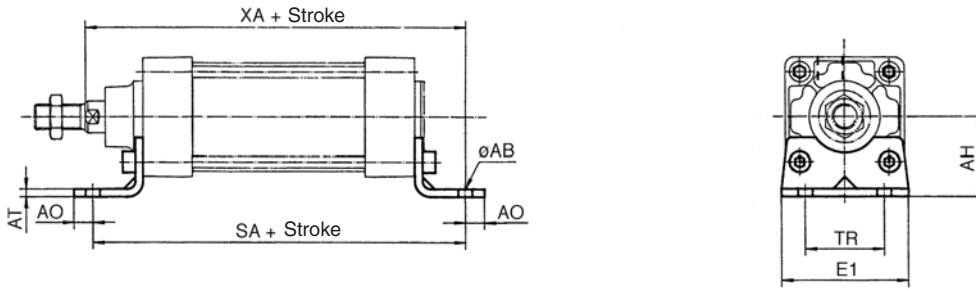

Center trunnion style (T)

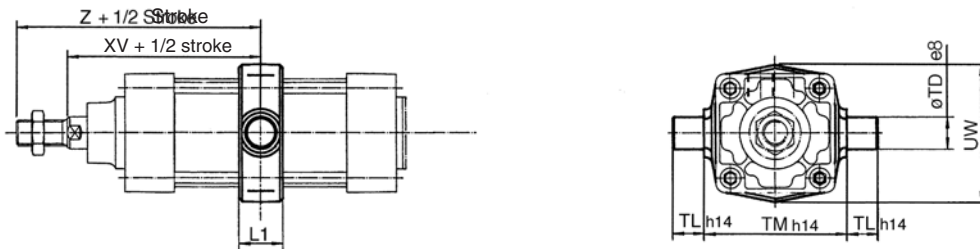

Flange style (F, G)

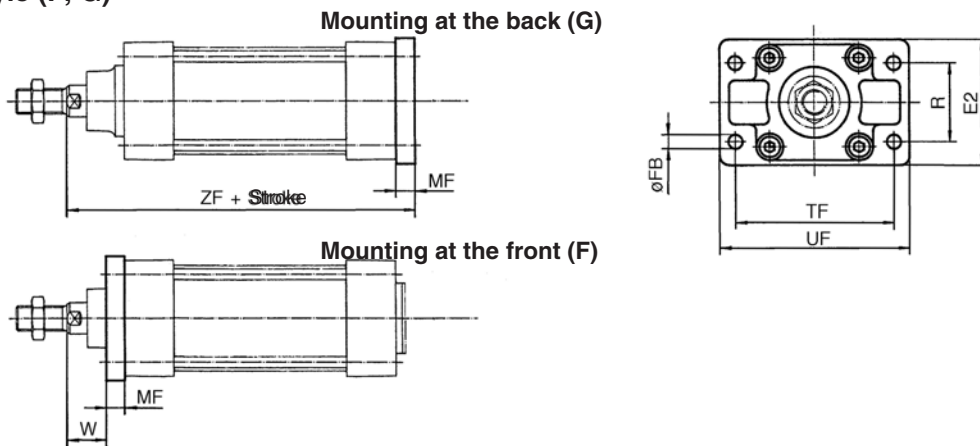

Head side single clevis style (C) Head side double clevis style (D)

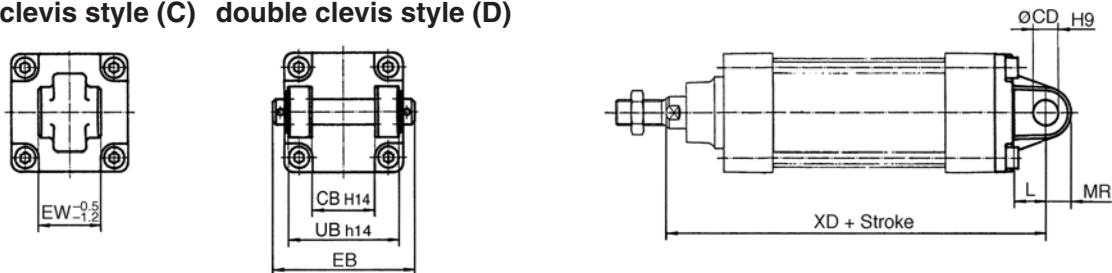

Bore (mm)	E1	R	W	MF	ZF	ϕFB	ϕCD H9	EB	L	XD	UB h14	CB h14	EW -0.5 / -1.2	MR	TR	AO	AT	XA	SA	AH	ϕAB	L1	XV	Z	TL h14	ϕTD e8	TM h14	UW	TF	UF	E2
160	Max. 195	115	60	20	280	18	30	Max. 209	Min. 35	315	170	90	90	Max. 31	115	Max. 25	9	320	300	115	18	Max. 50	170	242	32	32	200	Max. 220	230	Max. 280	Max. 195
200	Max. 238	135	70	25	300	22	30	Max. 209	Min. 35	335	170	90	90	Max. 31	135	Max. 35	12	345	320	135	22	Max. 50	185	257	32	32	250	Max. 260	270	Max. 320	Max. 238
250	Max. 290	165	80	25	330	26	40	Max. 249	Min. 45	375	200	110	110	Max. 41	165	Max. 40	14.5	380	350	165	26	Max. 60	205	289	40	40	320	Max. 320	330	Max. 395	Max. 290

Quick Reference Guide
 C55
 C85
 C76
 CP95
C95
 -X (Made to Order)
 D- (Auto Switch)
 Model Selection Procedures

Series C95

Dimensions: Cylinder Mounting Accessory C, D, E and CR

[First angle projection]

Mounting style (C)

Mounting style (D)

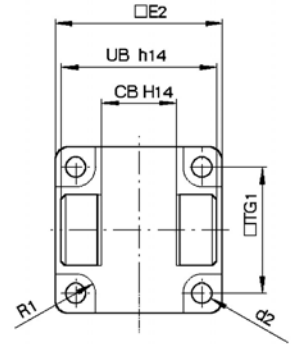
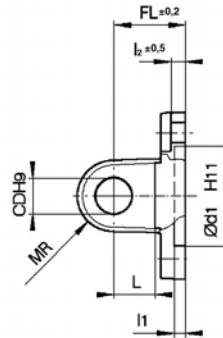
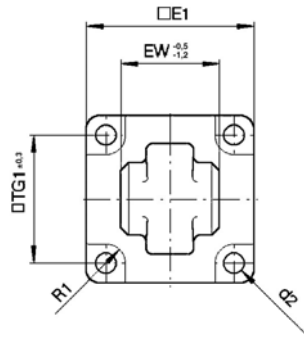
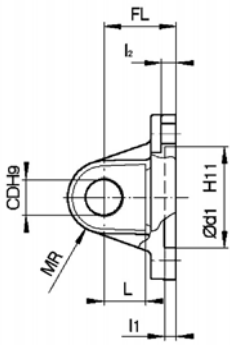

Bore size (mm)	□E1	EW	□TG1	FL	l ₁	l ₂	Ød1	CD	MR	d2	R1	□E2	UB	CB
160	180	90	140	55	7	10	65	30	25	18	13	180	170	90
200	220	90	175	60	7	11	75	30	25	18	13	220	170	90
250	270	110	220	70	11	11	90	40	40	22	16.5	270	200	110

Dimensions: Piston Rod Mounting Accessory

[First angle projection]

Piston Rod Clevis (ISO 8140)
 Steel, Zinc Chromate Plated

Part no.	Bore size (mm)	e	b	d	øf h11	L1 max.	c min.	a max.	L min.
GKM35-54	160/200	M36 x 2	35 $\begin{matrix} +0.60 \\ +0.15 \end{matrix}$	144	35	201	54	70	57
GKM40-84	250	M42 x 2	40 $\begin{matrix} +0.60 \\ +0.15 \end{matrix}$	168	40	245	84	85	77

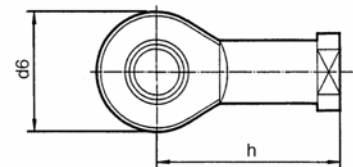
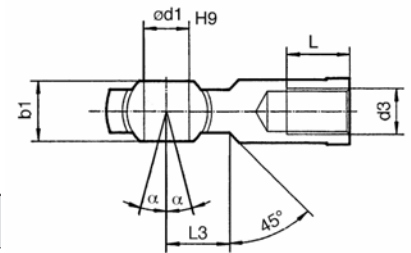
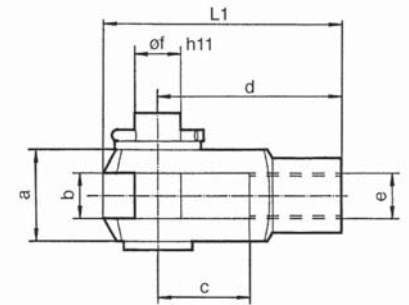

Piston Rod Ball Joint (ISO 8139)
 Steel, Zinc Chromate Plated

Part no.	Bore size (mm)	d3	d1 H9	h	d6 max.	b1 h12	L min.	α	L3
KJ36D	160/200	M36 x 2	35	125	80	43	56	16	55
KJ42D	250	M42 x 2	40	142	90	49	60	4	46

Dimensions: Piston Rod Mounting Accessory

[First angle projection]

Floating Joint JA
 Steel

Bore size (mm)	M	Part no.	A	B	C	øD	E	F	G	H	P	U	Load (kN)	Weight (g)	Angle
160, 200	M36 x 2	JA160-36-200	178	51	55	96	16	55	24	55	42	3	71	4700	5

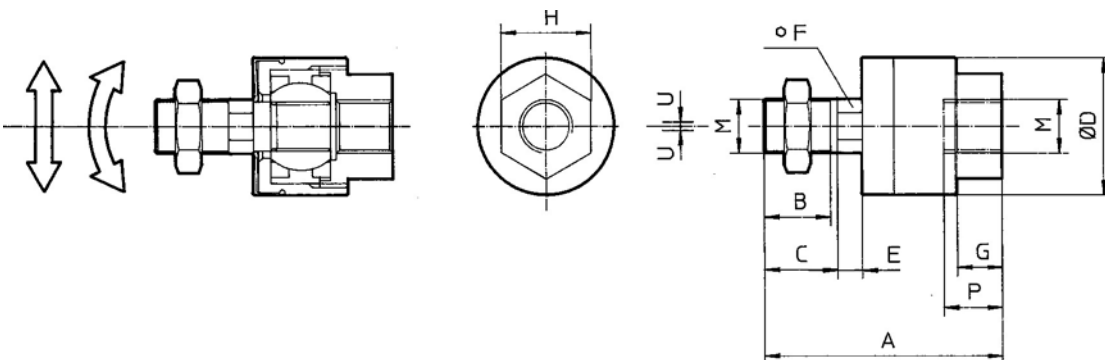

Quick Reference Guide

C55

C85

C76

CP95

C95

-X (Made to Order)

D- (Auto Switch)

Model Selection Procedures

Auto Switch Specifications

Applicable Auto Switch



Type	Auto switch model	Electrical entry (Function)
Reed switch	D-A5□/A6□	Grommet
	D-A59W	Grommet (2-color indication)
	D-Z7□/Z80	Grommet
	D-A3□	Terminal conduit
	D-A44	DIN terminal
Solid state switch	D-F5□/J5□	Grommet
	D-F5□W/J59W	Grommet (2-color indication)
	D-F5BAL	Grommet (2-color indication, Water resistant)
	D-F59F	Grommet (2-color indication, Diagnostic output)
	D-F5NTL	Grommet (With timer)
	D-Y59□	Grommet (In-line)
	D-Y69□	Grommet (Perpendicular)
	D-Y7P	Grommet (In-line)
	D-Y7PV	Grommet (Perpendicular)
	D-Y7□W	Grommet (2-color indication, In-line)
	D-Y7□WV	Grommet (2-color indication, Perpendicular)
	D-Y7BAL	Grommet (Water resistant, In-line)
	D-G39/K39	Terminal conduit

Minimum Stroke for Auto Switch Mounting

Auto switch model	No. of auto switches	Support bracket except center trunnion			Center trunnion		
		ø160	ø200	ø250	ø160	ø200	ø250
A5□ A6□	1, 2	10	10	10	125	125	145
	n	$10 + 55(n-2)/2$ n = 2, 4, 6, 8...	←	←	$125 + 55(n-4)/2$ n = 4, 8, 12, 16...	$125 + 55(n-4)/2$ n = 4, 8, 12, 16...	$145 + 55(n-4)/2$ n = 4, 8, 12, 16...
A59W	2	←	←	←	135	135	155
	n	←	←	←	$135 + 55(n-4)/2$ n = 4, 8, 12, 16...	$135 + 55(n-4)/2$ n = 4, 8, 12, 16...	$155 + 55(n-4)/2$ n = 4, 8, 12, 16...
F5□(W)/J5□/J59W F5BAL/F59F	1, 2	10	←	←	135	135	155
	n	$10 + 55(n-2)/2$ n = 2, 4, 6, 8...	←	←	$135 + 55(n-4)/2$ n = 4, 8, 12, 16...	$135 + 55(n-4)/2$ n = 4, 8, 12, 16...	$155 + 55(n-4)/2$ n = 4, 8, 12, 16...
F5NTL	1, 2	15	15	15	150	145	165
	n	$15 + 55(n-2)/2$ n = 2, 4, 6, 8...	←	←	$150 + 55(n-4)/2$ n = 4, 8, 12, 16...	$145 + 55(n-4)/2$ n = 4, 8, 12, 16...	$165 + 55(n-4)/2$ n = 4, 8, 12, 16...
A3□ K3□ G3□	1	10	10	—	140	140	—
	2 (Same side)	100	100	—	140	140	—
	2 (Different sides)	35	35	—	140	140	—
	n (Same side)	←	←	—	$140 + 100(n-2)$ n = 2, 4, 6, 8...	$140 + 100(n-2)$ n = 2, 4, 6, 8...	—
A44	n (Different sides)	←	←	—	$140 + 100(n-2)$ n = 2, 4, 6, 8...	$140 + 100(n-2)$ n = 2, 4, 6, 8...	—
	1	10	10	—	100	100	—
	2 (Same side)	55	55	—	100	100	—
	2 (Different sides)	35	35	—	100	100	—
Z7□/Z80	n (Same side)	←	←	—	$100 + 100(n-2)$ n = 2, 4, 6, 8...	$100 + 100(n-2)$ n = 2, 4, 6, 8...	—
	n (Different sides)	←	←	—	$100 + 100(n-2)$ n = 2, 4, 6, 8...	$100 + 100(n-2)$ n = 2, 4, 6, 8...	—
	1, 2	10	10	—	120	110	—
	n	←	←	—	$120 + 55(n-4)/2$ n = 4, 8, 12, 16...	$110 + 55(n-4)/2$ n = 4, 8, 12, 16...	—
Y59□/Y7P Y7□W	1, 2	10	10	—	110	110	—
	n	←	←	—	$110 + 55(n-4)/2$ n = 4, 8, 12, 16...	$110 + 55(n-4)/2$ n = 4, 8, 12, 16...	—
Y69□/Y7PV Y7□WV	1, 2	10	10	—	85	80	—
	n	←	←	—	$85 + 55(n-4)/2$ n = 4, 8, 12, 16...	$80 + 55(n-4)/2$ n = 4, 8, 12, 16...	—
Y7BAL	1, 2	10	10	—	120	120	—
	n	←	←	—	$120 + 55(n-4)/2$ n = 4, 8, 12, 16...	$120 + 55(n-4)/2$ n = 4, 8, 12, 16...	—

Auto Switch Mounting Position and Mounting Height

[First angle projection]



Auto Switch Mounting Position

Bore size (mm)	D-A5□ D-A6□		D-A59W		D-F5□, D-F5□W D-J5□, D-J59W D-F59F, D-F5BAL		D-F5NTL		D-Z7□, D-Y59□, D-Y7BAL D-Z80, D-Y69□ D-Y7P(V), D-Y7□W(V)		D-A3□, D-G39 D-A44, D-K39	
	A	B	A	B	A	B	A	B	A	B	A	B
160	19.5	18.5	23.5	22.5	26	25	31	30	23	22	19.5	18.5
200	17	17	21	21	23.5	23.5	28.5	28.5	20.5	20.5	17	17
250	20	30	24	34	26.5	36.5	31.5	41.5	—	—	—	—

Auto Switch Mounting Height

Bore size (mm)	D-A5□ D-A6□ D-A59W		D-F5□, D-F5□W, D-F5NTL D-J5□, D-J59W D-F59F, D-F5BAL		D-A3□, D-G39 D-K39		D-A44		D-Z7□, D-Y59□ D-Z80, D-Y7P D-Y7□W		D-Y69□ D-Y7PV D-Y7□WV		D-Y7BAL	
	Hs	Ht	Hs	Ht	Hs	Ht	Hs	Ht	Hs	Ht	Hs	Ht	Hs	Ht
160	90	86	89	86	134.5	—	144.5	—	84.5	83	84.5	83	89.5	83
200	102.5	104	102	104	154	—	164	—	100.5	100.5	100.5	100.5	103	100.5
250	127	128	127	128	—	—	—	—	—	—	—	—	—	—

Switch Hysteresis

Bore size (mm)	ON-OFF switch hysteresis	
	Reed switch	Solid state switch
160 to 200	≤ 2 mm	≤ 1 mm
250	≤ 3 mm	≤ 1 mm

Other than the applicable auto switches listed in “How to Order”, the following auto switches can be mounted. For detailed specifications, refer to page 8-1.

Type	Model	Electrical entry	Features
Solid state switch	D-F5NTL	Grommet (In-line)	With timer
	D-Y69A/Y69B/Y7PV	Grommet (Perpendicular)	—
	D-Y7NWV/Y7PWV/Y7BWV		2-color indication

* With pre-wire connector is available for solid state auto switches. For details, refer to page 8-1.

* Normally closed (NC = b contact), solid state switch (D-Y7G/Y7H type) are also available. For details, refer to page 8-1.



Series C95

Specific Product Precautions

Be sure to read before handling.

Adjustment

Warning

1. Do not open the cushion valve above the stopper.

Cushion valves are provided with a retaining ring ($\phi 160$ to $\phi 250$) as a stopping mechanism, and the cushion valve should not be opened above that point.

If air is supplied and operation started without confirming the above condition, the cushion valve may be ejected from the cover.

Bore size (mm)	Cushion valve	Width across flats	Socket wrench
160, 200, 250	MB-A2-10-EA064	4	JIS 4648 Hex spanner wrench 4

2. Be certain to activate the air cushion at the stroke end.

When it is intended to use the cushion valve in the fully opened position, select a style with a damper. If this is not done, the tie-rods or piston rod assembly will be damaged.

3. When replacing brackets, use the hexagon wrench shown below.

Bore size (mm)		Bolt	Width across flats	Tightening torque (Nm)
160, 200		M16 x 2 x 30l	14	99
250	Foot	M20 x 2.5 x 35l	17	193.5
	Others	M20 x 2.5 x 30l	17	